

# The NRC and Nuclear Power Plant Safety in 2013

*More Jekyll, Less Hyde*



[ Union of  
Concerned Scientists



# The NRC and Nuclear Power Plant Safety in 2013

*More Jekyll, Less Hyde*

David Lochbaum

March 2014

© 2014 Union of Concerned Scientists

All rights reserved

**David Lochbaum** is director of the Nuclear Safety Project for the UCS Global Security Program.

The Union of Concerned Scientists puts rigorous, independent science to work to solve our planet's most pressing problems. Joining with citizens across the country, we combine technical analysis and effective advocacy to create innovative, practical solutions for a healthy, safe, and sustainable future.

More information about UCS and the Nuclear Safety Project is available at the UCS website ([www.ucsusa.org](http://www.ucsusa.org)).

The full text of this report is available on the UCS website ([www.ucsusa.org/publications](http://www.ucsusa.org/publications)) or may be obtained from:

UCS Publications  
2 Brattle Square  
Cambridge, MA 02138-3780

Or email [pubs@ucsusa.org](mailto:pubs@ucsusa.org)  
or call 617-547-5552.

Cover photo: Blue light from the interaction of radiation with cooling water illuminates the core of a nuclear research reactor. (© U.S. Nuclear Regulatory Commission)

Printed on recycled paper

## [ CONTENTS ]

v Figures and Tables

vi Acknowledgments

### 1 EXECUTIVE SUMMARY

#### CHAPTER 1

### 3 The Cop on the Nuclear Beat

3 The Reactor Oversight Process and Near-Misses

6 The Scope of This Report

#### CHAPTER 2

### 7 Near-Misses at Nuclear Power Plants in 2013

7 Arkansas Nuclear One Units 1 and 2, AR

11 Browns Ferry Nuclear Plant Units 1, 2, and 3, AL

12 Columbia Generating Station, WA (First Incident)

12 Columbia Generating Station, WA (Second Incident)

12 Columbia Generating Station, WA (Third Incident)

14 Fort Calhoun Station, NE

15 LaSalle County Station Units 1 and 2, IL

19 Oyster Creek Nuclear Generation Station, NJ

21 Shearon Harris Nuclear Power Plant, NC

23 Susquehanna Steam Electric Station Unit 2, PA

26 Observations on the Near-Misses in 2013

#### CHAPTER 3

### 27 Trends from Near-Misses 2010–2013

	<b>CHAPTER 4</b>
30	<b>Positive Outcomes from NRC Oversight</b>
30	Connecting the Dots on Component Aging
31	Putting Georgia on Probation
31	Allowing Fort Calhoun to Restart
33	Not Doing What It Said It Would Do
33	Observations on Effective NRC Oversight
	<b>CHAPTER 5</b>
35	<b>Negative Outcomes from NRC Oversight</b>
35	Mismanaging the Spent Fuel Pool Risk
38	Conspiring to Delay Safety Fixes at Oconee
39	Allowing Diablo Canyon to Operate
41	Improperly Hiding Information
43	Observations on Ineffective NRC Oversight
	<b>CHAPTER 6</b>
45	<b>Summary and Recommendations</b>
47	<b>References</b>

## [ FIGURES AND TABLES ]

### FIGURES

- 9 Figure 1. Near-Misses in 2013 by Cornerstones of the Reactor Oversight Process
- 16 Figure 2. Electrical Distribution System at the LaSalle Nuclear Plant
- 22 Figure 3. Metal Tubes Penetrating the Reactor Vessel Head
- 25 Figure 4. The Bathtub Curve
- 35 Figure 5. Fukushima Public Meetings
- 37 Figure 6A. Risk from Spent Fuel Pool Storage
- 37 Figure 6B. Risk from Dry Storage
- 42 Figure 7. Risk of Core Damage at Oconee from Various Threats

### TABLES

- 5 Table 1. Seven Cornerstones of the Reactor Oversight Process
- 8 Table 2. Near-Misses at Nuclear Power Plants in 2013
- 28 Table 3. Near-Misses 2010–2013

## [ ACKNOWLEDGMENTS ]

This report was made possible through the generous support of the Park Foundation and members of the Union of Concerned Scientists (UCS).

The author greatly appreciates the peer reviews of the draft report conducted by Paul Blanch, an electrical engineer who retired from the nuclear industry after a long and distinguished career; Arnie Gundersen, chief engineer for Fairewinds Energy (<http://fairewinds.org>); and Lucas W. Hixson, the editor-in-chief of *Enformable Nuclear News* ([www.enformable.com](http://www.enformable.com)). The technical editing by Teri Grimwood, program researcher at UCS, was extremely helpful and much appreciated. Trudy E. Bell did a great job with the meticulously helpful final editing as she had done with last year's report in this series. And Bryan Wadsworth, publications director at UCS, deserves much credit for facilitating the editing, layout, and printing of the report on a very tight schedule.

The opinions expressed herein do not necessarily reflect those of the organizations that funded the work or the individuals who reviewed it.







# Robert Louis Stevenson’s classic *Strange Case of Dr. Jekyll and Mr. Hyde*, first published in 1886, dealt with the split personality experienced by the friendly and mild-mannered Dr. Henry Jekyll and his alter ego, the evil Mr. Edward Hyde.

Stevenson’s short novel is brought to mind by the apparent dual personality and bizarre behavior traits of the U.S. Nuclear Regulatory Commission (NRC).

On one hand, the NRC is a fair and effective regulator, establishing and enforcing safety regulations that subject neither nuclear plant owners to undue burdens nor workers and the public to undue risks. While no one can count the number of accidents that the NRC’s efforts have averted, the trend over the past three decades in the declining number of “near-misses” and safety problems is highly suggestive that much of the time the agency does its job well. On the other hand, the NRC sometimes acts as if it is channeling Mr. Hyde.

Inconsistencies in the NRC’s actions and inactions last year (2013) invoked both Jekyll and Hyde. As described below in Chapter 2, the NRC’s inspectors repeatedly compelled the owner of the Columbia Generating Station to identify and correct the underlying causes of recurring problems with a vital air conditioning unit. But after identifying several examples of inadequate procedures and training at the LaSalle nuclear plant, the NRC’s inspectors let the owner off the hook entirely. Yet, when very similar problems surfaced at the H.B. Robinson and Browns Ferry nuclear plants, the NRC compelled the owners to rectify the deficiencies.

The strange cases of the Fort Calhoun and Diablo Canyon nuclear plants provide further evidence of the NRC’s dichotomy. As described below in Chapter 4, the NRC did not allow the Fort Calhoun reactor in Nebraska to operate until known safety shortcomings were corrected. Yet as described in Chapter 5, the NRC allowed the two reactors at the Diablo

Canyon plant in California to continue operating despite its owner failing to resolve known safety shortcomings. The unresolved problems at Diablo Canyon involve inadequate protection against earthquakes. When similar earthquake protection deficiencies were identified at the Beaver Valley, Humboldt Bay, Maine Yankee, San Onofre, Surry, and West Valley nuclear facilities, the NRC’s Dr. Jekyll ordered them shut down until their owners had provided adequate protections against the earthquake hazards. Yet today, the NRC’s Mr. Hyde allows Diablo Canyon to operate despite the known risks.

Giving the NRC the benefit of doubt, one might assume there are nuances explaining why entirely opposite reactions to the same set of facts can somehow both be right. The strange case of Oconee clearly shows this is not the case. As described in Chapter 5, the NRC approved an amendment to the operating licenses for the three reactors at the Oconee Nuclear Station in Seneca, South Carolina, in 2010 contingent on its owner completing safety fixes by December 31, 2012. The owner asked the NRC in July 2012 for permission to extend this deadline by two years. In January 2013, the NRC’s Dr. Jekyll denied the request on the grounds that the risk was too high to allow the fixes to be delayed that long. But in July 2013, the NRC’s Mr. Hyde ordered the company to complete the fixes no later than November 15, 2016—nearly two years after the owner’s initial extension request that had been rejected as being too unsafe.

A second strange case of Oconee covered in Chapter 5 involved the NRC’s Dr. Jekyll formally requiring the plant’s owner in June 2010 to take more than a dozen measures to

lessen the chances that the upstream Jocassee Dam (owned by the same company) could fail and to better protect the plant against flooding in the event the dam fails anyway. The NRC's justification for this mandate included its determination that if the dam failed, there was a 100 percent chance that flooding would cause the three reactors at Oconee to melt down. The NRC's Mr. Hyde then intervened to improperly withhold all the correspondence about this hazard from the public. Worse still, the NRC conducted its annual public meeting in the community near the Oconee nuclear plant in April 2011, a month after tsunami flooding caused three reactors at Japan's Fukushima Daiichi Nuclear Power Station to melt down. The exact same flooding hazard that exists

today at the Oconee nuclear plant was not mentioned by the NRC—so the public was actually misled into believing no such problems existed.

To be sure, the NRC is far more Jekyll than Hyde, as evidenced by the improving trends over the past three decades. But with so many American lives at stake, even a cameo appearance by the NRC's Mr. Hyde is too much. If an earthquake near Diablo Canyon or a failure of the Jocassee Dam harmed people, the NRC would be unable to look Americans in the eyes and honestly claim it had taken every reasonable measure to prevent the disaster.

More Jekyll, less Hyde is this critic's choice for the NRC's future.

## The Cop on the Nuclear Beat

The U.S. Nuclear Regulatory Commission (NRC) is to owners of nuclear reactors what local law enforcement is to a community. Both are tasked with enforcing safety regulations to protect people from harm. A local police force would let a community down if it investigated only murder cases while tolerating burglaries, traffic violations, and vandalism. The NRC must similarly be the cop on the nuclear beat, actively monitoring reactors to ensure they are operating within regulations, and aggressively engaging owners and workers over safety violations whether small, medium, or large.

The Union of Concerned Scientists (UCS) has evaluated safety issues at nuclear power plants in the United States for over 40 years. We have repeatedly found that NRC enforcement of safety regulations is not timely, consistent, or effective. Our findings match those of the NRC's own internal assessments, as well as of independent agents such as the NRC's Office of the Inspector General and the federal Government Accountability Office (GAO). Seldom does an internal or external evaluation conclude that a reactor incident or unsafe condition stemmed from a lack of regulations. Like UCS, these evaluators instead consistently find that the NRC's enforcement of existing regulations is inadequate.

We have also repeatedly found the NRC to be capable of enforcing its safety regulations. Because we believe the NRC's problem to be consistency rather than capability, we feel the appropriate remedy is to help the agency move toward more consistent and aggressive enforcement.

This report—like its predecessors—chronicles what the agency is doing right as well as what it is doing wrong. Our

goal is to help the NRC achieve more of the former and avoid more of the latter.

### The Reactor Oversight Process and Near-Misses

The NRC monitors safety levels at nuclear plants using its Reactor Oversight Process (ROP). In this process, the NRC's full-time inspectors assess operations and procedures, attempting to detect problems before they become more serious. The ROP features seven cornerstones of reactor safety (Table 1, p. 5). Using this process, the NRC issued nearly 200 reports on its findings last year alone.<sup>1</sup>

When an event occurs at a reactor or a degraded condition is discovered, the NRC evaluates the chance of damage to the reactor core. A key nuclear safety principle called defense-in-depth means that many protective measures must fail for the reactor core to be damaged. The NRC estimates the degree to which the event or degraded condition has reduced the number of protective measures preventing core damage. Most incidents at nuclear power plants have low risk. If the event or condition did not affect that risk—or if the risk was increased only by a very small amount—the NRC relies on routine measures in the ROP to respond.

When an event or condition increases the chance of reactor core damage by a factor of 10, however, the NRC is likely to send out a special inspection team (SIT). When the risk rises by a factor of 100, the agency dispatches an augmented inspection team (AIT). And when the risk increases

---

<sup>1</sup> See [http://www.nrc.gov/NRR/OVERSIGHT/ASSESS/listofrpts\\_body.html](http://www.nrc.gov/NRR/OVERSIGHT/ASSESS/listofrpts_body.html) for the NRC's safety inspection reports.

***NRC inspection teams are dispatched only when something is believed to have increased the chances of such an accident by at least a factor of 10.***

by a factor of 1,000 or more, the NRC sends an incident inspection team (IIT). Because they are in response to an event or discovery at a site, the NRC considers its SIT, AIT, and IIT efforts to be reactive inspections (NRC 2011).

When an event or discovery at a reactor results in the NRC sending out a team for a reactive inspection, UCS refers to it as a “near-miss.” Over the years, using this label has proven to be more controversial than expected. UCS continues to use this term because it indicates a clear nexus to accidents involving core damage: the NRC inspection teams are dispatched only when something is believed to have increased the chances of such an accident by at least a factor of 10. In other words, the NRC dispatches inspection teams

when it believes safety margins have been significantly reduced, placing the reactor closer to an accident. “Near-miss” seems a more appropriate and more accurately illustrative label than the NRC’s own term, “accident sequence precursor.”

When NRC inspection teams are sent out, they go to a site to investigate what happened, why it happened, and whether the incident poses any safety implications for other nuclear plants. The teams take many weeks to conduct an investigation, evaluate the information they gather, and document their findings in a publicly available report.

Both routine ROP inspections and investigations by the special teams may identify violations of NRC regulations. The NRC classifies violations in five categories, with Red



© U.S. Nuclear Regulatory Commission

*The NRC conducts routine inspections of nuclear plants and investigates unusual events at the plants.*

TABLE 1. Seven Cornerstones of the Reactor Oversight Process

Initiating Events	Conditions that, if not properly controlled, require the plant’s emergency equipment to maintain safety. Problems in this cornerstone include improper control over combustible materials or welding activities, causing an elevated risk of fire; degradation of piping, raising the risk that it will rupture; and improper sizing of fuses, raising the risk that the plant will lose electrical power.
Mitigating Systems	Emergency equipment designed to limit the impact of initiating events. Problems in this cornerstone include ineffective maintenance of an emergency diesel generator, degrading the ability to provide emergency power to respond to a loss of offsite power; inadequate repair of a problem with a pump in the emergency reactor-core cooling system, reducing the reliability of cooling during an accident; and non-conservative calibration of an automatic temperature set point for an emergency ventilation system, delaying its startup longer than safety studies assume.
Barrier Integrity	Multiple forms of containment preventing the release of radioactive material into the environment. Problems in this cornerstone include foreign material in the reactor vessel, which can damage fuel assemblies; corrosion of the reactor vessel head; and malfunction of valves in piping that passes through containment walls.
Emergency Preparedness	Measures intended to protect the public if a reactor releases significant amounts of radioactive material. Problems in this cornerstone include emergency sirens within 10 miles of the plant that fail to work, and underestimation of the severity of plant conditions during a simulated or actual accident, delaying protective measures.
Public Radiation Safety	Design features and administrative controls that limit public exposure to radiation. Problems in this cornerstone include improper calibration of a radiation detector that monitors a pathway for the release of potentially contaminated air or water to the environment.
Occupational Radiation Safety	Design features and administrative controls that limit the exposure of plant workers to radiation. Problems in this cornerstone include failure to survey an area properly for sources of radiation, causing workers to receive unplanned exposures; and incomplete accounting of individuals’ radiation exposure.
Security	Protection against sabotage that aims to release radioactive material into the environment; this can include gates, guards, and guns. After 9/11, the NRC removed discussion of this cornerstone from the public arena.

SOURCE: SEE [WWW.NRC.GOV/REACTORS/OPERATING/OVERSIGHT/ROP-DESCRIPTION.HTML](http://WWW.NRC.GOV/REACTORS/OPERATING/OVERSIGHT/ROP-DESCRIPTION.HTML).

denoting the most serious, followed by Yellow, White, Green, and Non-Cited Violations.<sup>2</sup>

The color assigned by the NRC for a violation is sometimes related to how much it increased the risk of reactor core damage. But many violations do not lend themselves to such numerical analysis, such as those associated with inadequate radiation protection of plant workers. In general, Red findings from the NRC reflect highest risk and lower performance while Green findings indicate lowest risk and higher performance. The NRC issues non-cited violations not just as oxymorons. Instead, non-cited violations flag situations that do not rise to even the Green threshold, but that reflect

unacceptable behavior the NRC wants plant management to correct.

For certain violations that do not lend themselves to classification by their risk significance, the NRC uses four severity levels, with level I being the most severe and level IV the least serious. For example, the NRC’s regulations prohibit the falsification of maintenance and test documents. The NRC’s security regulations require protection against sabotage. It is difficult to assess how violations of either of these regulations might affect core damage risk, and thus how to assign the appropriate color. In such cases, the NRC assigns severity levels instead, considering such factors as whether senior managers

<sup>2</sup> For security violations (as opposed to safety violations), the NRC uses a “Greater than Green” classification instead of White, Yellow, and Red labels to convey to the public some distinction about the seriousness of security problems without also pointing potential saboteurs to plants having especially serious security vulnerabilities.

were aware of or involved in the violations and whether the violations were caused by deliberate acts or sloppy practices.

The classifications dictate the thoroughness of the responses the NRC expects from plant owners as well as the extent of the NRC's follow-up to the violations. For example, for a Green finding, a plant owner would be expected to fix the non-conforming condition and NRC inspectors might verify proper resolution during their next planned examination of that area, whether that opportunity was scheduled within a month or a year. For a Yellow or Red finding, however, the plant owner would be expected to also take steps to determine whether the problem was an isolated case or reflective of a broader, programmatic breakdown. Moreover, the NRC's follow-up inspections are typically more timely for Yellow and Red findings than for Green and White findings.

***This detailed review of all the near-misses reported in 2013 provides important insights into trends in nuclear safety.***

### **The Scope of This Report**

Chapter 2 summarizes the near-misses at nuclear reactors that the NRC reported in 2013, although some actually occurred in 2012. Near-misses are events that prompted the agency to dispatch an SIT, AIT, or IIT. In these events, a combination of broken or impaired safety equipment and poor worker training typically led owners of nuclear plants down a pathway toward potentially catastrophic outcomes. After providing an overview of each event, this chapter shows how one problem led to another in more detail for that event, and notes any “tickets” the NRC wrote for safety violations that contributed to the near-miss.

This detailed review of all the near-misses reported in 2013 provides important insights into trends in nuclear safety, as well as into the effectiveness of the NRC's oversight process. For example, if many near-misses stemmed from failed equipment, such as emergency diesel generators, the NRC could focus its efforts in that arena until it arrests declining performance. Chapter 2 therefore uses the year's safety-related events to suggest how the NRC can prevent



*NRC inspectors at the Browns Ferry plant in Alabama.*

© U.S. Nuclear Regulatory Commission

plant owners from accumulating problems that may conspire to cause next year's near-misses—or worse.

With the near-misses attesting to why day-to-day enforcement of regulations is vital to the safety of nuclear power, the subsequent three chapters then highlight the NRC's own performance in monitoring safety through the reactor oversight process. Chapter 3 evaluates trends from the near-misses since 2010 when UCS initiated the ROP series of reports. Chapter 4 describes occasions in which effective oversight by NRC inspectors led to actions to prevent safety problems from snowballing into near-misses or even more dangerous situations. Chapter 5 then describes cases where ineffective NRC oversight failed to prevent dangerous situations—or actually set the stage for them.

Chapter 6 summarizes findings from the near-misses in Chapter 2, the trend analysis of Chapter 3, the examples of positive outcomes from the reactor oversight process in Chapter 4, and the examples of negative outcomes from that process in Chapter 5. This concluding chapter notes which oversight and enforcement strategies worked well for the NRC in 2013 and which did not. Furthermore, Chapter 6 recommends steps the NRC should take to reinforce behavior among plant owners leading to commendable outcomes, and steps the NRC should take to alter behavior that produces outcomes that pose risks to employees and the public.

Our primary aim in creating these annual reports on nuclear reactor safety is to spur the NRC to improve its own performance as well as that of reactor owners.



## Near-Misses at Nuclear Power Plants in 2013

In 2013, the NRC reported on 10 events, summarized in Table 2 (p. 8), that prompted the agency to send teams to analyze problems at those reactors.<sup>3</sup> Nine of these events triggered investigations by special inspection teams (SIT) in response to a 10-fold increase in risk of core damage, and one triggered an augmented inspection team (AIT) inspection in response to a 100-fold increase in risk of core damage. No events in 2013 triggered an incident inspection team (IIT) inspection in response to a 1,000-fold or greater increase in risk of core damage.

UCS considers all 10 events near-misses because they raised the risk of damage to the reactor core—and thus to the safety of workers and the public. As the end of this chapter will show, lessons from these near-misses reveal how the NRC can apply its limited resources to reap the greatest returns for public safety.

***Lessons from these near-misses reveal how the NRC can apply its limited resources to reap the greatest returns for public safety.***

In 2013, reports from the SITs and AIT dispatched by the NRC identified 19 violations of NRC safety regulations. Figure 1 (p. 9) classifies these violations by the seven cornerstones of the ROP.<sup>4</sup>

Each near-miss reported by the NRC in 2013 is described below in alphabetical order by plant name (matching the order in Table 2).

### Arkansas Nuclear One Units 1 and 2, AR

#### THE NEAR-MISS

The NRC sent an AIT to the plant after a temporary crane moving the generator stator on Unit 1 collapsed. The heavy load fell through the turbine building floor, killing one worker and injuring eight others. The dropped load also caused Unit 1 to be disconnected from the offsite power grid and caused the Unit 2 reactor to automatically shut down from full power (Howell 2013).

#### HOW THE EVENT UNFOLDED

The operators shut down the Unit 1 reactor on March 24, 2013, to enter a refueling outage. In addition to replacing some of the fuel assemblies in the reactor core with fresh fuel, many testing and maintenance tasks were being performed during the outage. These tasks included refurbishing the main generator.

<sup>3</sup> Numbering becomes cumbersome because some nuclear plants can have multiple reactors, events can affect one or more reactors at a plant, and some plants experienced multiple events. Table 2 here and Table 3 later in the report attempt to clarify who experienced what near-miss.

<sup>4</sup> For more information on the cornerstones and related NRC inspections, see Table 1 and <http://www.nrc.gov/NRR/OVERSIGHT/ASSESS/cornerstone.html>.

TABLE 2. Near-Misses at Nuclear Power Plants in 2013

Reactor and Location	Operator	Highlights
<b>Arkansas Nuclear One Units 1 and Unit 2</b> London, AR	Entergy Operations, Inc.	AIT: A crane moving a heavy component during a refueling outage on Unit 1 collapsed. The component fell through an opening in the floor into the turbine building's basement. Debris disabled electrical equipment that caused Unit 2 to automatically shut down from full power and left Unit 1 disconnected from the offsite power grid.
<b>Browns Ferry Nuclear Plant Units 1, 2 and 3</b> Athens, AL	Tennessee Valley Authority	SIT: Security problems prompted the NRC to conduct a special inspection. Details of the problems, their causes, and their fixes are not publicly available.
<b>Columbia Generating Station</b> Benton County, WA (first incident)	Energy Northwest	SIT: Security problems prompted the NRC to conduct a special inspection. Details of the problems, their causes, and their fixes are not publicly available.
<b>Columbia Generating Station</b> Benton County, WA (second incident)	Energy Northwest	SIT: Security problems prompted the NRC to conduct a special inspection. Details of the problems, their causes, and their fixes are not publicly available.
<b>Columbia Generating Station</b> Benton County, WA (third incident)	Energy Northwest	SIT: An air conditioning unit for rooms containing essential electrical equipment was found degraded due to inadequate maintenance and testing practices.
<b>Fort Calhoun Station</b> Fort Calhoun, NE	Omaha Public Power District	SIT: Workers replacing rusted bolts used to anchor a cooling water pump to the concrete floor discovered the anchorage configuration did not conform to the design specification and would not properly support the equipment against forces during an earthquake.
<b>LaSalle County Station Units 1 and 2</b> Marseilles, IL	Exelon Generation Co., LLC	SIT: A lightning strike near the plant caused an electrical disturbance that disconnected both units from the offsite power grid. The response to the dual-unit shutdowns revealed some procedure and operator training deficiencies.
<b>Oyster Creek Nuclear Generating Station</b> Forked River, NJ	Exelon Generation Co., LLC	SIT: Hurricane Sandy caused high water levels and disconnected the plant from its offsite power grid.
<b>Shearon Harris Nuclear Power Plant</b> New Hill, NC	Duke Energy	SIT: Workers preparing for inspections to be conducted during an upcoming refueling outage reviewed results from inspections conducted during the last refueling outage and found indications of cracks in tubes passing through the reactor vessel head that had not been fixed. The reactor was shut down for the repairs.
<b>Susquehanna Steam Electric Station Unit 2</b> Salem Township, PA	PPL Susquehanna, LLC	SIT: Workers replaced the original analog control system for the pumps providing makeup flow to the reactor vessel with a digital system. During a reactor startup, deficient procedures and training prevented the operators from using the pumps to supply sufficient flow to the vessel. The reactor automatically shut down when the water level inside the vessel dropped too low.

The main generator consists of a solid metal cylinder called the rotor that fits inside a tube-like enclosure called the stator. Steam flowing past metal fan-like blades spins the turbine. The turbine's shaft is connected to the rotor. The rotor spinning inside the stator produces the electricity that flows out via transmission lines to residential and commercial customers.

Workers installed a temporary crane at the plant to move the 525-ton stator. At 7:50 a.m. on March 31, the temporary crane collapsed. The stator fell about 18 inches to the turbine building floor, then rolled and fell through an opening in the turbine building floor. It fell about 30 feet onto a transporter,

which had been placed there to carry it offsite. The accident killed one worker and injured eight others.

The force of the impact deformed the structure supporting the floor. Debris fell onto electrical cabinets on the floor below, disabling them and disconnecting Unit 1 from its offsite power grid (these electrical cabinets formed key links between the offsite power grid and equipment throughout the plant). Both of the Unit 1 emergency diesel generators automatically started and restored power to essential equipment.

The systems cooling the Unit 1 reactor and spent fuel pool, however, were not automatically repowered by the

FIGURE 1. Near-Misses in 2013 by Cornerstones of the Reactor Oversight Process

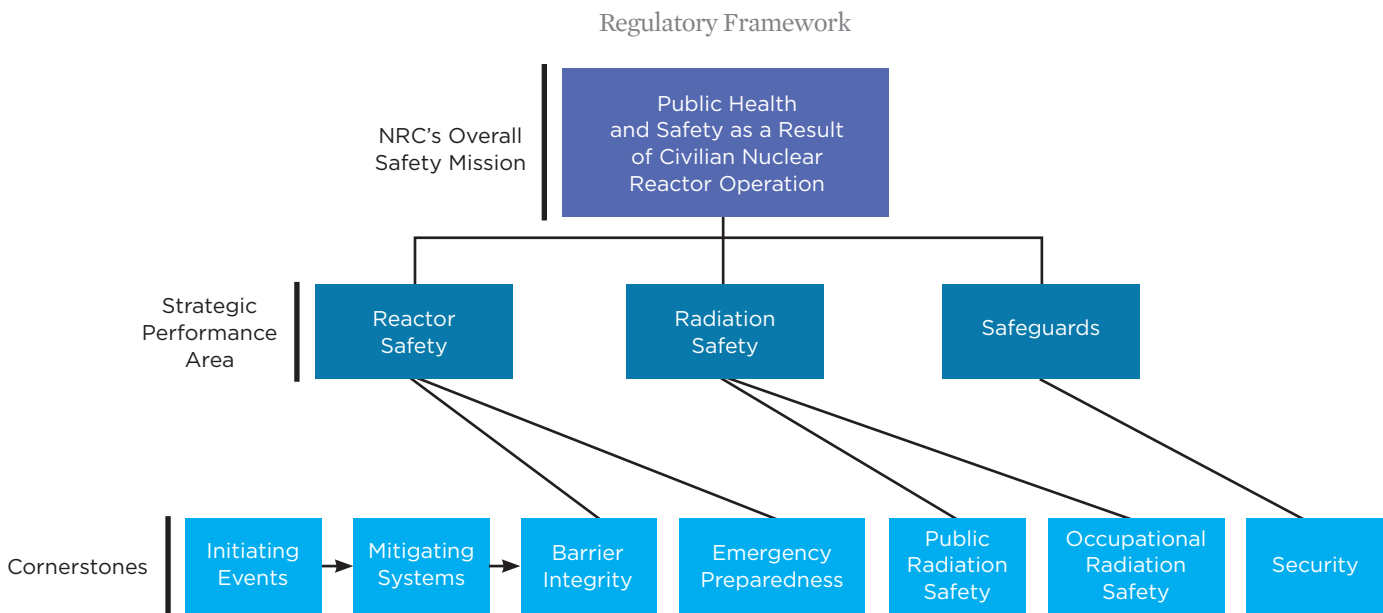

Near-Miss Category	Initiating Events	Mitigating Systems	Barrier Integrity	Emergency Preparedness	Public Radiation Safety	Occupational Radiation Safety	Security
Red	0	0	0	0	0	0	0
Yellow	0	0	0	0	0	0	0
White	0	0	0	0	0	0	0
>Green*	n/a	n/a	n/a	n/a	n/a	n/a	0
Green	1	14	0	1	0	0	0
Level IV	0	1	1	0	0	0	1
<b>Total</b>	<b>1</b>	<b>15</b>	<b>1</b>	<b>1</b>	<b>0</b>	<b>0</b>	<b>1</b>

\* After 9/11, the NRC stopped publicly releasing the color assigned to security violations; instead it indicates that a violation is "greater than Green."

SOURCE: U.S. NUCLEAR REGULATORY COMMISSION (TOP HALF OF FIGURE).



© Bob Webster/Wikimedia

An accident moving heavy equipment at the Arkansas Nuclear One power plant led to the only AIT in 2013.

emergency diesel generators. Therefore, cooling of the irradiated fuel in the reactor vessel and spent fuel pool stopped. The operators partially restored reactor core cooling in six minutes and fully restored it 10 minutes later. The temperature of the water inside the reactor vessel had not increased significantly during the brief loss of cooling.

The operators initially restored spent fuel pool cooling about 90 minutes later, but had to turn it back off after five minutes due to a problem on the Unit 2 side. The operators corrected this problem and restarted spent fuel pool cooling an hour later. The spent fuel pool's water temperature had risen about 3°F in the meantime.

The Unit 2 problem was this: Vibrations caused when the stator fell onto the turbine building floor and then again onto the ground floor opened the electrical breaker supplying power to the motor of reactor coolant pump B on Unit 2. The pump stopped running and significantly reduced the amount of cooling water flow entering the reactor vessel. By design, a protection system sensed this condition and automatically shut down the Unit 2 reactor from full power.

In addition, the stator falling through the opening in the turbine building floor to the ground floor also ruptured an 8-inch diameter pipe providing water to fire sprinklers inside the building. Water spraying from the broken pipe wetted nearby electrical equipment. As a result, some electrical

circuits for Unit 2 equipment, including the system cooling the Unit 2 spent fuel pool, shorted out. One of the emergency diesel generators for Unit 2 automatically started. The operators restored the spent fuel pool cooling system two hours and 24 minutes later. The temperature of the Unit 2 spent fuel pool water had not changed while the cooling system was out of service.

For this refueling outage, workers installed a temporary fire pump and connected it to the fire suppression system piping. In response to the dropped stator rupturing the fire system pipe, the operators turned off the permanent fire pumps to stop the flow of water from the broken pipe and the damage it was causing. The temporary fire pump continued to run for another 40 minutes before the operators turned it off and stopped the water flow onto the turbine building's ground floor.

The partial loss of electrical power for Unit 2 also de-energized the air compressors. Nuclear plants use compressed air to operate some equipment, such as the valves used to spray cool water when necessary to control pressure inside the reactor vessel, and the valves used to vent steam to the atmosphere following a reactor shutdown. The operators used a procedure that had never been used except in the control room simulator to cool down the reactor water at a rate between 20°F and 30°F per hour (comfortably below the maximum limit of 100°F per hour).

Following the accident, extensive efforts were undertaken to inspect structures and equipment for damage caused by the dropped load and flood water. Repairs or replacements were made when necessary (Howell 2013).

Workers restarted the Unit 2 reactor on April 28. Repairs of the more extensive damage to Unit 1 prevented its reactor from restarting before August 7.

#### NRC SANCTIONS

The NRC's AIT identified no violations (Howell 2013).

#### UCS PERSPECTIVE

This near-miss was extremely unfortunate because it claimed a worker's life and injured eight other workers.

The tragedy's silver lining was in the commendable response by workers on both units. The near-miss resulted in

***Each problem posed challenges and increased stress levels. Yet workers successfully met the series of challenges.***

structural damage, internal flooding, loss of electrical power on both units, and the partial loss of the compressed air system. Each problem posed challenges and increased stress levels. Yet workers successfully met the series of challenges.

The failure to recognize that the temporary fire pump continued putting water out of the ruptured fire system piping was the only blemish on the impressive response record. Given all that was happening concurrently, it is a very minor blemish. That this problem was the principal flaw in the response—given all the challenges presented—serves as a testimonial to the response’s overall success.

The NRC and the nuclear industry expend considerable effort trying to learn lessons from accidents and near-misses. Doing so identifies communication problems, procedure inadequacies, training deficiencies, design and installation errors, and other factors that made bad days worse. The NRC and the nuclear industry would equally benefit from lessons that can be learned from responses that made bad days better. Emulating what to do is the flip side of the coin of emulating what not to do.

## **Browns Ferry Nuclear Plant Units 1, 2, and 3, AL**

### **THE NEAR-MISS**

The NRC sent an SIT to the plant in response to the potential tampering of a fuel oil line for an emergency diesel generator that was discovered on May 26, 2013. Reflecting the NRC’s post-9/11 procedures, the SIT report on the problems and their remedies is not publicly available. However, the cover letter sent to the plant owner with the SIT report is publicly available, and indicates that the agency identified one violation it classified as Severity Level IV (Reis 2013a).

### **UCS PERSPECTIVE**

The scant information publicly available about this security near-miss prevents any meaningful commentary.



*Potential security issues led to an inspection at the Browns Ferry nuclear plant in Alabama.*

© U.S. Nuclear Regulatory Commission

## Columbia Generating Station, WA (First Incident)

### THE NEAR-MISS

The NRC sent an SIT to the plant in response to a security-related issue that arose on February 6, 2013. Reflecting the NRC's post-9/11 procedures, the SIT report on the problems and their remedies is not publicly available. However, the cover letter sent to the plant owner with the SIT report is publicly available, and indicates that the agency identified no violations or significant findings (Haire 2013b).

### UCS PERSPECTIVE

The scant information publicly available about this security near-miss prevents any meaningful commentary.

## Columbia Generating Station, WA (Second Incident)

### THE NEAR-MISS

The NRC sent an SIT to the plant in response to a security-related issue that arose on September 12, 2013. Reflecting the NRC's post-9/11 procedures, the SIT report on the problems and their remedies is not publicly available. However, the cover letter sent to the plant owner with the SIT report is publicly available, and indicates that the agency identified no violations or significant findings (Haire 2013a).

### UCS PERSPECTIVE

The scant information publicly available about this security near-miss prevents any meaningful commentary.

## Columbia Generating Station, WA (Third Incident)

### THE NEAR-MISS

The NRC sent an SIT to the plant after workers discovered that the air conditioning unit for a room containing essential electrical equipment had become degraded to the point it might not have been able to prevent the equipment from overheating and failing.

Federal regulations require plant owners to qualify electrical equipment such as relays, sensors, breakers, and motors for the environmental conditions it will experience during both normal operation and accidents. Air handling unit WMA-AH-53A was installed in the Columbia Generating

Station to maintain air temperatures between 55°F and 104°F in several vital rooms. A fan circulated air from the rooms past water-filled tubes for cooling. The air handling unit also featured a heater to warm the air in the rooms when necessary (Lantz 2013). If a room's temperature dropped below 55°F or rose above 104°F, electrical components might fail or malfunction.

A roll-type filter installed upstream of the water-filled tubes protected them from fouling due to debris carried by the air. Fresh filter media on the supply spool moves into place when needed and the old filter media, along with the debris it collected, winds onto another spool. The roll-type filter includes a retainer downstream of the filter itself to collect material if the filter were to break apart; in other words, the retainer downstream of the filter is provided to prevent the protective filter media from fouling the water-filled tubes. It typically took about four years for a roll-type filter to be used up and require replacement (Lantz 2013).

On May 24, 2013, workers visually inspected the cooling tubes in air handling unit WMA-AH-53A about two weeks into the unit's refueling outage. They found three of the 22 tubes clogged with silt and debris. That discovery prompted them to re-inspect the outside of the tubes. They found considerable debris, including large pieces of the roll-type filter.

The plant owner initially estimated that the fouling on both the air and water side of the air handling unit's water-filled tubes reduced its heat exchange performance to 30 percent of performance under pristine conditions. The plant's safety studies assumed degradation would drop no lower than 65 percent of optimal performance (Lantz 2013).

The ensuing investigations revealed that workers replaced the roll-type filter on air handling unit WMA-AH-53A six months earlier, on November 15, 2012. The procedure lacked sufficient details to prevent the workers from installing the



Columbia Generating Station in Washington topped this year's list with three incidents that led to special inspections.

© U.S. Nuclear Regulatory Commission

replacement filter backwards (that is, with its retainer upstream of the filter). Thus, when the filter media broke apart, the retainer was unable to prevent air flow from carrying the pieces downstream to foul the water-filled tubes.

The investigations also identified breakdowns in the owner's maintenance and inspection practices for air handling units. While procedures required workers to visually inspect the air side of air handling units every two years, they did not require workers to remove the roll-type filters. Without removing the filters, the visual inspections could not possibly verify the condition of the tubes because the filters blocked the view. Thorough inspections had not been conducted since 2002 (Lantz 2013).

The water-filled tubes of the air handling units used a sacrificial coating. This coating protected the thin metal walls of the tubes from erosion and corrosion. But as the coating wore away, it created debris that could clog the tubes. The vendor recommended replacing and/or refurbishing the tubes every six years; yet, some of the tubes had been in service at the Columbia Generating Station for 17 years without any attention (Lantz 2013).

#### **NRC SANCTIONS**

The SIT documented five violations involving the mitigating systems cornerstone (Lantz 2013):

- Failure to evaluate the cause of the degradation of the air handling units. Workers removed the debris found in the air handling unit, but it took intervention by NRC inspectors to compel the evaluation of the programmatic causes of this safety problem.
- Failure to evaluate the extent of degradation problems caused by the sacrificial coatings applied to water-filled tubes in the air handling units. Between 2010 and 2012, workers had identified recurring problems with flow blockage in essential cooling units, but it took pressure from NRC inspectors to connect the dots and reveal the longstanding maintenance and inspection deficiencies causing these problems.
- Failure to adequately test the water-filled tubes in the air handling units. The testing procedures used prior to summer 2013 were not thorough enough to detect performance degradation.
- Failure to properly install roll-type filters in the air handling units. The procedures relied on skill-of-the-craft in lieu of detailed, specific installation guidance, contributing to the replacement error made in November 2012.

***Between 2010 and 2012, workers had identified recurring problems with flow blockage in essential cooling units, but it took pressure from NRC inspectors to connect the dots.***

- Failure to properly test and maintain a safety-related heating, ventilation, and air conditioning system. Before the degraded air handling unit was fully fixed in May 2013, it was put back in operation and its only backup removed from service in order to stay on the refueling schedule. NRC inspectors questioned the prudence of this action.

The NRC classified all five violations as Green (Lantz 2013). The violations allowed essential components to be degraded, but calculations performed by the plant owner and reviewed by the NRC SIT showed that safety margins, while reduced, had not been compromised.

#### **UCS PERSPECTIVE**

The NRC resident and SIT inspectors performed commendably in this case. The plant owner repeatedly narrowed the scope of the problem and its resolution. But NRC inspectors steadfastly rejected “band-aid” fixes, requiring that the underlying causes be identified and fixed.

This event involved the return of a safety problem believed to have been resolved decades ago. In 1989, the NRC issued Generic Letter 89-13 to all plant owners. The NRC described safety problems identified in the mid- to late 1980s with air and water cooling units and required plant owners to take steps to prevent their recurrence (Partlow 1989).

The NRC's SIT reported that several of the “fixes” implemented at the Columbia Generating Station in response to Generic Letter 89-13 had subsequently been undone or undermined. In other words, the promises back then to do X, Y, and Z had transformed during the intervening years into now either doing A, B, and C or not doing anything at all. The failure to replace the cooling unit tubes every six years as recommended by the vendor illustrates the problem that is being addressed by the commendable outcome achieved by the NRC last year as described in the “Connecting the Dots on Component Aging” section in Chapter 4.



© Armoedanus/Wikimedia

Workers at the Fort Calhoun nuclear plant in Nebraska found that pumps for circulating cooling water had been improperly installed.

The NRC should periodically inspect past fixes to determine whether they continue to adequately protect against recurrence of past safety problems. This near-miss at Columbia is not an isolated instance where the NRC learned after the fact that past fixes had been undone or undermined. The agency should be more proactive in its oversight efforts.

## Fort Calhoun Station, NE

### THE NEAR-MISS

The NRC sent an SIT to the plant after learning that the methods used to install the raw water pumps deviated from the approved design and would not properly support the pumps from forces during an earthquake (Hay 2013).

### HOW THE EVENT UNFOLDED

The raw water system at the Fort Calhoun nuclear plant in Nebraska uses four electric-motor-powered pumps to draw water from the Missouri River and route it through the plant to cool essential equipment during an accident. Each pump is secured in place using nuts tightened onto 18-inch-long bolts partially embedded in the concrete floor. The installation protects the pumps and motors during routine operation and from shaking forces applied during earthquakes.

On December 2, 2012, maintenance workers prepared to replace a rusted bolt used to anchor one of the raw water pumps. The system engineer reviewed paperwork used to construct the pump house back in the late 1960s to check for

possible interferences, such as metal reinforcing bars, before workers chipped away concrete to remove the rusted bolt and embed a new one. The system engineer identified a discrepancy between how the raw water pumps had actually been anchored and the configuration that had been assumed in safety studies.

In February 1987 the NRC had required owners of older nuclear plants, including Fort Calhoun, to re-assess protection against earthquakes using its recently revised acceptance criteria. On October 28, 1993, workers completed the earthquake re-analysis for the raw water pumps using an incorrect configuration for how the pumps were anchored to the floor (Hay 2013).

In September 2009, NRC inspectors reviewed the earthquake re-analysis for the raw water pumps and found several non-conservative errors. The NRC cited the company for violating 10 CFR 50 Appendix B by using the wrong anchor bolt configuration in its earthquake re-analysis. The company redid the re-analysis using the correct configuration.

In June 2010, workers at Fort Calhoun completed an analysis of the consequences from a postulated scenario involving a barge in the Missouri River hitting the intake structure. Their analysis used the incorrect anchor bolt configuration for the raw water pumps, repeating the mistake made in the analysis completed in October 1993 (Hay 2013).

The NRC's SIT examined the designs for several other installations at Fort Calhoun to ascertain whether the raw water pump anchorage problem was isolated or indicative of broader problems. This effort revealed other design discrepancies as noted below.



## NRC SANCTIONS

The SIT documented seven violations involving the mitigating systems cornerstone:

- Failure to match the as-built design for the raw water pump anchorage configuration with the associated safety studies.
- Failure to ensure the as-built design for the raw water pump anchorage met applicable American Concrete Institute standards.
- Failure to correct a situation where stresses for raw water system piping exceeded levels specified in applicable codes.
- Failure to provide an adequate design of supports for raw water system piping.
- Failure to match the as-built design of supports for raw water system piping with the associated safety studies.
- Failure to provide an adequate design for the structural supports for the containment air coolers.
- Failure to match the as-built design of supports for electrical switchgear cabinets with the associated safety studies.

The NRC classified all seven violations as Green (Hay 2013). The violations involved various failures to properly document that the as-built plant had appropriate safety margins. The violations would likely have been classified more severely had the problems not been identified by workers and thereby resulted in actual failure of one or more raw water pumps.

## UCS PERSPECTIVE

The NRC renewed the license for Fort Calhoun on November 4, 2003, authorizing the reactor to operate until August 2033.<sup>5</sup> The NRC's license renewal process assumes that reactors seeking 20-year renewals comply with all design and licensing requirements. Consequently, the NRC's review is narrowed to evaluating only whether effective processes are in place to prevent age-related degradation from eroding safety margins during the period of extended operation. This Fort Calhoun near-miss is another example of the flawed process the NRC uses to relicense aging reactors.

The supreme irony is that this Fort Calhoun near-miss exactly mirrors the fundamental flaw in the NRC's license renewal process. At Fort Calhoun, workers assumed an

anchorage configuration that did not exist when they performed safety studies of earthquake and barge impact hazards. Consequently, the results from their efforts were invalid. NRC workers assumed a situation that did not exist when they performed safety studies of the extended operation hazard. They falsely assumed that Fort Calhoun complied with all applicable regulatory requirements, yet the reactor has been shut down since April 2011 while armies of workers endeavor to achieve compliance. In other words, the NRC should not have relicensed Fort Calhoun in 2003 with so many safety violations existing but undetected and uncorrected. Not looking for safety problems is the easiest and surest way to miss them.

The NRC compelled Fort Calhoun to fix its deficiencies. For the exact same reasons, Congress should compel the NRC to fix nearly identical deficiencies in its license renewal process.

## LaSalle County Station Units 1 and 2, IL

### THE NEAR-MISS

The NRC sent an SIT to the site after a lightning strike caused an electrical disturbance that resulted in both reactors automatically shutting down. After the reactors shut down, the operators declared some emergency systems on both units inoperable (Reynolds 2013).

### HOW THE EVENT UNFOLDED

At 2:57 p.m. on April 17, 2013, lightning struck one of the two 138,000-volt transmission lines leaving the LaSalle switchyard (denoted by the red flash on Figure 2, p. 16). An electrical breaker opened automatically to limit the ripple effect from the power surge induced by the lightning. After the event, workers found evidence suggesting that the surge arced or flashed over a transformer (TR-81) before the breaker opened.

The electrical disturbance affected a bank of batteries housed in a nearby structure. After the event, an investigation determined that poor workmanship during the original construction of the 138,000-volt switchyard facilitated degradation of the grounding system protecting the batteries (Vinyard 2013). These batteries controlled the electrical breakers for the two 138,000-volt transmission lines as well as the electrical

---

<sup>5</sup> See <http://www.nrc.gov/reactors/operating/licensing/renewal/applications/ft-calhoun.html> for additional information about the Fort Calhoun relicensing process. The operating license for Fort Calhoun would have expired in August 2013. The NRC allows owners to apply for license renewal up to 15 years before expiration in order to provide time to pursue alternate electricity generation options should a renewed license not be approved.

FIGURE 2. Electrical Distribution System at the LaSalle Nuclear Plant

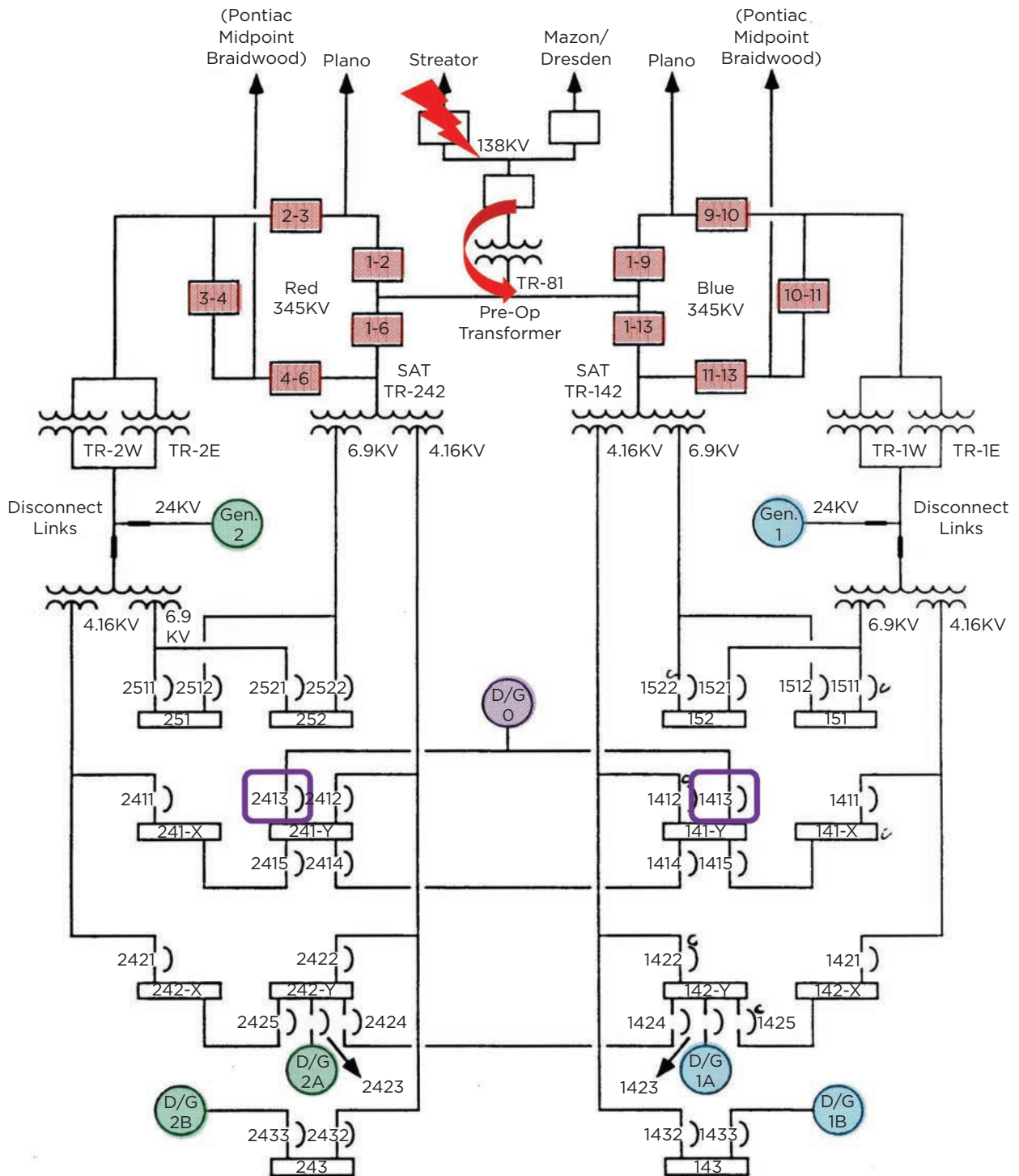

Electricity produced by the two reactors' generators (Gen. 1 on the right and Gen. 2 on the left) flows upward to the switchyard and out to the offsite power grid through six transmission lines. Electricity also flows downward to supply various electric buses, or circuits, for in-plant use.

SOURCE: U.S. NUCLEAR REGULATORY COMMISSION.



A shutdown of the reactors at the LaSalle plant in Illinois by a lightning strike led to the discovery that workers lacked training on important emergency systems.

breakers for four 345,000 volt transmission lines. The problem with the batteries opened 10 electrical breakers (indicated by the shaded rectangles in Figure 2) about two minutes after the lightning strike. There was no need for the breakers to open and they should have remained closed.

The opened electrical breakers disconnected LaSalle from its offsite power grid. This condition triggered the automatic shutdown of both reactors and the automatic startup of all five emergency diesel generators (each unit has two dedicated emergency diesel generators—D/G 1A and 1B for Unit 1 and D/G 2A and 2B for Unit 2—while one emergency diesel generator (D/G 0) can be connected to both units.

As described in the report (Reynolds 2013) by the NRC’s SIT, Section 8.2.3.2 of the Updated Final Safety Analysis Report (UFSAR)—the compilation of safety studies that the NRC reviewed in reaching its determination that the plant complied with all applicable regulatory requirements and could be issued an operating license—states, “The switchyard arrangement is such that offsite power to both units cannot

be lost due to any single failure.” And UFSAR section 8.1.2.5 states, “The design of the protective relay circuits for the 345-kV oil circuit breakers and the 345-kV transmission lines is such that the loss of either battery or the loss of both batteries and associated feeder cable will not cause the loss of offsite power source.” Contrary to these design basis requirements, offsite power was lost to both units when a single failure caused both batteries to be lost.

The operators used the reactor core isolation cooling (RCIC) systems to provide makeup water to the Unit 1 and 2 reactor vessels and the safety/relief valves (SRVs) to control pressure inside the reactor vessels. These were the expected steps to be taken in response to the situation.

Ninety-three minutes after the reactors shut down, the operators were unable to start residual heat removal (RHR) pump 2C on Unit 2. (The RCIC system uses a steam-driven pump and its exhaust steam flows into the suppression pool water. Similarly, the steam discharged from the reactor vessel through opened SRVs flows into the suppression pool water.)

***Poor workmanship during the original construction of the 138,000-volt switchyard facilitated degradation of the grounding system protecting the batteries.***

The operators had been using the RHR system to cool the water inside the suppression pools on both units. The operators declared the pump inoperable. The operators were able to start RHR pumps 2A and 2B and place them into suppression pool cooling mode.

The NRC's SIT reported that, "Weaknesses in licensed operator knowledge of the low pressure coolant injection (LPCI) system response (in particular, the 2C RHR pump) . . . were apparent during the event and warrant additional attention by the licensee to improve through training" (Reynolds 2013). In other words, the pump functioned exactly as designed—the operators just did not understand how to turn it on.

control pressure inside the reactor vessel. After that second valve did not open, the operators declared it inoperable.

The NRC's SIT reported that the "SRVs and SRV position indication functioned as expected during the event" (Reynolds 2013). In other words, the safety relief valves functioned as designed—the operators just did not understand how to use them.

At 7:24 pm, workers re-connected station auxiliary transformer TR-242 to offsite power. At 8:26 pm, station auxiliary transformer TR-142 was re-connected to offsite power. Workers began returning power supplies within the plant to their normal configuration and removing supplies from the emergency diesel generators.

***The NRC's SIT determined that licensed control room operators lacked adequate understanding of how the residual heat removal pumps and safety relief valves function.***

Two hours and 22 minutes after the reactors shut down, pressure inside the Unit 2 dry well had risen so high that venting automatically stopped. (The loss of offsite power de-energized the normal cooling system for the dry well. The operators opened containment vent valves—the valves that figured prominently in the three reactor meltdowns at Fukushima in March 2011—to control the rising pressure as the dry well atmosphere heated up. But the pressure inside the Unit 2 dry well rose to the point where the vent valves automatically closed. Because the high pressure might have been caused by water jetting from a broken pipe connected to the reactor vessel, the containment vent valves automatically closed to block radioactivity in that water from escaping into the environment.) High dry well pressure terminated containment venting on Unit 1 five hours and five minutes after the reactor shut down.

Two hours and 46 minutes after the reactors shut down, the operators experienced unexpected performance of the Unit 1 safety/relief valves. An operator attempted to manually open an SRV to control pressure inside the reactor vessel, as had been periodically done since the reactor shut down, but an electrical signal from the valve indicated it had remained closed. Because the reactor pressure decreased as anticipated following an SRV opening, the operators declared the valve's position indication system inoperable.

Three hours and 22 minutes after the reactors shut down, an operator on Unit 1 attempted to open a different SRV to

Between midnight and 1 a.m. on April 18, workers restarted the normal cooling system for the Unit 1 and Unit 2 dry wells. The resumption of cooling reduced the pressure and temperature inside both dry wells.

At 1:25 p.m. on April 18, an operator attempted to raise the water level inside the Unit 1 reactor vessel using the low-pressure core spray pump. But the injection valve failed to open, preventing makeup water from this emergency pump from reaching the reactor vessel. The NRC's SIT reported that the control switch for the pump was broken. In other words, the operators understood how the pump worked, but were unable to get it to work.

At 2:00 p.m. on April 18, workers discovered water leaking from a pipe in the Unit 2 high-pressure core spray system and declared this emergency system inoperable.

Unit 1 reached cold shutdown (reactor water temperature less than 200°F) at 5:58 p.m. on April 18; Unit 2 reached cold shutdown at 2:50 a.m. on April 19.

Workers replaced the seals on the two recirculation pumps for Unit 2 during the outage. Each recirculation pump is a large electric-motor-driven pump located inside the containment building that supplies tens of thousands of gallons of water every minute to the reactor vessel. The seals prevent water leaking from the reactor vessel—if the seals fail, about 60 gallons per minute can leak into containment. High temperatures damage the seals. The system cooling the seals was out of service for about three and a half days following the

loss of offsite power. In the meantime, the temperature of the recirculation pump seals was literally off the charts—too high to be recorded. The potentially degraded seals were replaced before restarting the Unit 2 reactor. (The cooling system for the Unit 1 recirculation pump seals had been out of service for only about 30 minutes.)

Workers restarted the Unit 2 reactor on April 24 and the Unit 1 reactor on April 29.

#### **NRC SANCTIONS**

The NRC identified one violation in the mitigating systems cornerstone. The company failed to report the failure of the low-pressure core spray pump's injection valve to open within eight hours as required by 10 CFR 50.72(a)(1). The NRC classified this violation at Severity Level IV.

#### **UCS PERSPECTIVE**

The NRC's SIT determined that licensed control room operators lacked adequate understanding of how the residual heat removal pumps and safety relief valves function, but did not find any violations associated with this cluelessness, so did not assign a color to the near-miss.

Quoting tennis champion John McEnroe, "You cannot be serious!"

These pumps and valves are among the most important emergency equipment at the plant. For example, the NRC conducted a three-week inspection at LaSalle in late 2010 "that focused on the design of components that are risk-significant and have low design margin" (Stone 2011). This large effort (very few NRC inspections—a small handful at most—involve three weeks or more of onsite investigation) examined 16 high-risk components in detail. The NRC's "smart sample"<sup>6</sup> included the residual heat removal pump. It is regulatory roulette for the NRC to ensure that the residual heat removal pumps are properly designed, properly installed, and properly maintained and then not be concerned when it discovers that control room operators do not understand how to properly use the pumps.

Federal regulations require owners to have adequate procedures backed by effective training to guide control room operators when responding to plant events. The NRC's SIT documented clear violations of these regulatory requirements with respect to the residual heat removal pumps and safety relief valves, but failed to cite them—in spite of the fact that the NRC has issued violations for very similar failings in the past.

On January 31, 2011, the NRC issued a violation to the owner of the H.B. Robinson Steam Electric Plant in Hartsville, South Carolina, for the "failure to adequately design and implement operator training based on learning objectives as required by 10 CFR 55.59(c), in that training lesson material failed to identify the basis of a procedural action involving reactor coolant pump seal cooling" (McCree 2011).

On August 13, 2012, the NRC issued a violation to the owner of the Browns Ferry nuclear plant in Alabama for not "adequately performing an evaluation of training needs. As a result, the systems approach to training was not properly implemented and the procedures could not be satisfactorily performed by plant operators and staff" (McCree 2012).

The LaSalle, H.B. Robinson, and Browns Ferry events involved no fuel damage or harm to workers or the public. All the events involved deficient procedures and training that prevented the operators from properly using safety equipment. The NRC issued violations classified as White findings for the Robinson and Browns Ferry miscues; the NRC gave a free pass for the very same problems at LaSalle.

Arbitrary and capricious citation of violations has absolutely no place in nuclear safety decision making and must be eliminated.

## **Oyster Creek Nuclear Generation Station, NJ**

#### **THE NEAR-MISS**

The NRC sent an SIT to the site after Hurricane Sandy caused an abnormally high water level and caused the site to lose its supply of electricity from the offsite power grid.

#### **HOW THE EVENT UNFOLDED**

On October 22, 2012, operators shut down the reactor to enter a refueling outage. At 9:20 a.m. on October 28, Sandy's storm surge along the Atlantic coast pushed up the Forked River, causing an abnormally high water level at the intake structure where the plant obtained cooling water during normal operation and under accident conditions. At 1:46 p.m. the following day, winds at the plant site gusted to more than 58 miles per hour.

By 6:55 p.m. on October 29, the water level had risen to the point where the operators declared an Unusual Event—the least serious of the NRC's four emergency classifications.<sup>7</sup> Workers notified local, state, and federal officials about the

<sup>6</sup> "Smart sample" refers to the nuclear industry practice of examining the components or manual actions having the highest risk—in other words, to be most likely to contribute to a reactor meltdown if they fail—so as to extract the greatest safety value from the inspection investment.

<sup>7</sup> The NRC's four emergency classifications, in order of increasing severity, are Unusual Event, Alert, Site Area Emergency, and General Emergency.

emergency declaration and conditions at the plant. (After the event, it was discovered that workers recorded the wrong wind direction. Had conditions worsened to the point where significant amounts of radioactivity were released, local and state officials rely on the wind direction reported at the site when making decisions about evacuating citizens or advising them to take shelter in place.)

One of the transmission lines connecting the plant to the offsite power grid failed at 7:54 p.m. on October 29. Some equipment inside the plant, including the system cooling the spent fuel pool water, stopped running due to loss of power. The system cooling the water inside the reactor vessel continued running. At this point during the refueling outage, the reactor vessel and spent fuel pool were physically connected to form one large volume of water. Calculations showed that it would take about 28 hours for this water to heat up and begin boiling if all cooling systems stopped running.

At 8:18 p.m. that evening, the plant lost all sources of offsite power. More equipment inside the plant, including the system cooling the water inside the reactor vessel, stopped running as almost all power within the plant was lost, at least momentarily. Both of the plant's emergency diesel generators started running and re-supplied electricity to essential equipment.

The operators upped the emergency classification to an Alert at 8:44 p.m. because the water level at the intake structure reached about seven feet above normal.

Workers restarted the system cooling the water inside the reactor vessel at 8:50 p.m. and the system cooling the spent fuel pool at 9:19 p.m.

Flooding levels at the site rose to within 29 inches of the motors for the service water pumps by 11:27 p.m. The service water pumps supplied cooling water to the emergency diesel generators and other essential equipment, but would be disabled if water submerged their electric motors. The water level peaked at 12:18 a.m. on October 30 at 28 inches from the service water pump motors and began dropping.

The plant was partially resupplied by electricity from the offsite power grid at 9:47 a.m. on October 30. The plant was fully reconnected to offsite power sources at 3:17 a.m. on October 31 (Hunegs 2013).

#### **NRC SANCTIONS**

The NRC classified the violation involving the wrong wind direction being recorded by emergency response workers as Green. Because the event did not involve a release of radioactivity, this mistake had no actual implications.



*Oyster Creek nuclear plant in New Jersey lost offsite electrical power following Hurricane Sandy.*

© U.S. Nuclear Regulatory Commission

#### **UCS PERSPECTIVE**

Nature drove flooding levels at the plant to within 28 inches of disabling the normal and backup cooling systems for the reactor core and spent fuel pool. There is normally 10 feet of margin, but Sandy took away nearly 80 percent of that safety cushion.

This event reinforced the wisdom of being prepared for the unexpected, in case anyone missed that lesson from Fukushima. What if this storm, or the next one, pushed flooding levels up another 28 inches or more? Would workers have been as helpless as those at Fukushima, or could they have relied upon other equipment protected from storm damage to take over and prevent fuel damage?

In the wake of Fukushima, the NRC ordered plant owners to take several steps by year-end 2016 and is studying several other steps intended to reduce vulnerabilities to severe challenges. But IOUs protect no one. The sooner these

safety upgrades move from the road ahead to the rearview mirror, the better.

## Shearon Harris Nuclear Power Plant, NC

### THE NEAR-MISS

The NRC sent an SIT to the site after operators shut down the reactor on May 15, 2013. Workers reviewing results from inspections conducted in spring 2012 of metal tubes passing through the head of the reactor vessel identified degradation that should have been fixed, but was not (Reis 2013b).

### HOW THE EVENT UNFOLDED

In spring 2001, workers at the Oconee Nuclear Station in Seneca, South Carolina, found evidence that a metal tube, called a control rod drive mechanism nozzle, passing through the reactor vessel head had leaked cooling water. The leak occurred due to age-related degradation (i.e., cracking) in a location not previously experienced. Inspection protocols used within the industry at that time only examined the J-groove welds connecting the tubes to the inside surface of the reactor vessel head. Those connections were intact at Oconee, but a tube cracked and leaked above that point as shown in Figure 3 (p. 22). Thus, the NRC required owners of similar reactors, including Shearon Harris, to examine larger portions of the tubes and inspect the tubes more frequently.

During a refueling outage in spring 2012, workers at Shearon Harris identified four cracked nozzles. None of the cracks went completely through the nozzles' walls to leak cooling water. Workers repaired all four nozzles to restore the necessary safety margin against leakage.

In May 2013, workers at Shearon Harris prepared for the refueling outage scheduled for the fall. The Electric Power Research Institute (EPRI) was hired to review the results from the spring 2012 inspections to help plan the upcoming inspection effort.

The EPRI notified the company that the inspection data showed a fifth nozzle to be cracked, but it had not been repaired. The company brought in AREVA Inc. for a second opinion. AREVA confirmed the EPRI's finding,

Workers evaluated the degraded condition represented by the cracked nozzle and justified continued operation based on lack of indications of cooling water leaking into the containment.

During a conference call, staff in NRC Region II challenged the company's assumption that the crack had not propagated into a vulnerable region. The inspection results had not definitely characterized the crack and the company had simply assumed it was confined to a low-risk region.

The company checked with AREVA about the NRC's concerns. AREVA reported there was a greater than 50 percent chance that the crack had penetrated into the higher-risk region. Based on AREVA's evaluation, the company shut down the reactor within hours.

***Hurricane Sandy reinforced the wisdom of being prepared for the unexpected, in case anyone missed that lesson from Fukushima.***

Subsequent inspections determined that the nozzle had a crack that was 0.314 inch long and 0.154 inch deep (or about 25 percent of the thickness of the nozzle's wall). The results also showed that the crack had indeed extended into the higher-risk region.

The NRC's SIT examined how the crack indication had been misdiagnosed during the spring 2012 outage. The procedure used by plant workers conducting the spring 2012 inspections called for inspection results to be independently evaluated by two qualified analysts. However, the analysts sat side by side during the reviews and may have performed reviews together instead of separately. Additionally, one analyst had worked 24 days straight without a day off while the second had worked 17 straight days (Reis 2013b).

In 2008, the NRC imposed limits on working hours to protect against human performance impairment due to fatigue.<sup>8</sup> Both analysts worked many more hours than specified in the regulation. Bowing to industry pressure, the NRC applied the work hour limits only to workers at operating reactors; thus, the workers could work up to 24/7 for as long as the reactor remained shut down.

Workers repaired the cracked nozzle. The unit was connected to the electrical grid on June 7 to end the three-week outage.

<sup>8</sup> See <http://www.nrc.gov/reading-rm/doc-collections/cfr/part026/part026-0205.html> for the work hour limits and applicability.

FIGURE 3. Metal Tubes Penetrating the Reactor Vessel Head

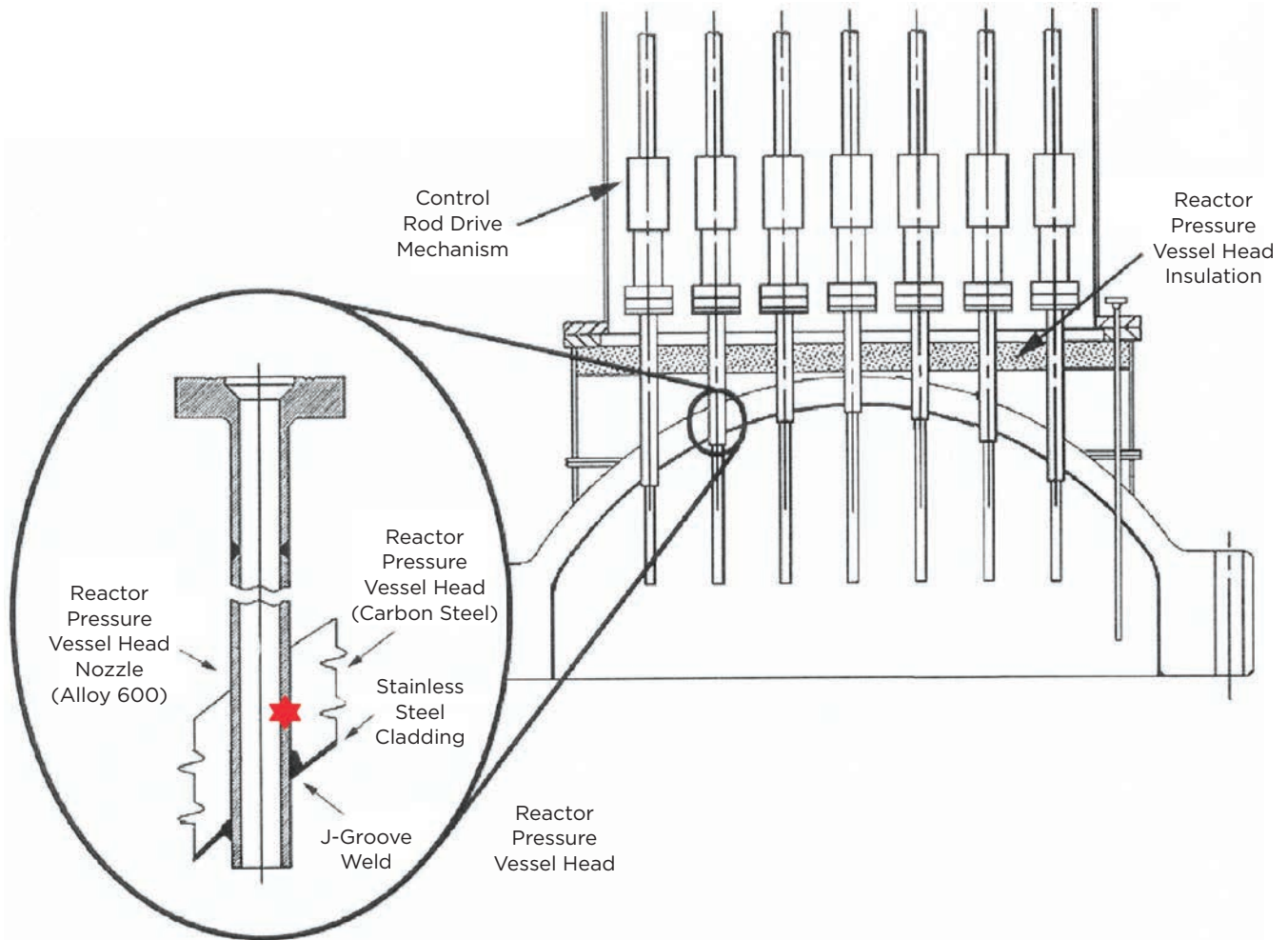

*Cross-section view of the reactor vessel head showing the vertical metal tubes that penetrate the head, allowing control rod drive mechanisms (essentially motors) to be connected to control rods within the reactor core. The red star in the insert shows where a tube at Oconee cracked and leaked.*

SOURCE: U.S. NUCLEAR REGULATORY COMMISSION.

### NRC SANCTIONS

The NRC identified one Severity Level IV violation in the barrier integrity cornerstone because the company failed to submit a written report (called a licensee event report) to the NRC about the degraded component within 60 days as required by 10 CFR Part 50.73(a)(2)(ii)(A) (Reis 2013b). The NRC started the 60-day clock on April 27, 2012, when workers obtained inspection results showing the cracked nozzles, but failed to properly interpret the results and repair the damage (Reis 2013b).

### UCS PERSPECTIVE

Shearon Harris operated for nearly a year with a degraded condition that, when finally considered properly, resulted in the reactor being shut down within hours for safety reasons. The plant obviously operated at undue and elevated risk during that entire time.

Both the NRC and the company had measures in place to prevent such an outcome, yet it happened. The NRC required all the nozzles to be inspected during each refueling outage. The company inspected all the nozzles during the spring 2012



refueling outage. The company had two qualified analysts review the results for each nozzle. They identified four cracked nozzles that were repaired. They missed one cracked nozzle—and the reactor was restarted without its being repaired. In nuclear safety, 80 percent is not a passing grade.

The NRC's and the company's response to this near-miss will minimize mistakes like this one happening again. The NRC dispatched an SIT, signaling to the entire industry the seriousness of this problem. The company shut down Shearon Harris for three weeks to effect the necessary repairs. It becomes easier to justify the expense of more robust measures and backup verifications when weighed against the cost of an unplanned three-week outage.

The two analysts had worked for 17 and 24 straight days prior to making their mistakes during the spring 2012 refueling outage. The NRC's work-hour regulations do not permit such prolonged work periods—but those limits do not apply when reactors are shut down. Legally, workers can be on the job 24/7 until the reactor restarts or until they die from exhaustion, whichever comes first.

The NRC's regulations require that workers performing testing and inspections at nuclear power plants be properly qualified and trained.<sup>9</sup> These regulatory requirements are not diminished or suspended when a reactor shuts down. For the same reasons, the NRC's regulations protecting workers from impairment due to fatigue must not be relaxed simply because a reactor has shut down. Mistakes made by fatigued workers are not magically erased when reactors restart. It is irresponsible for the NRC to set the stage for nuclear accidents by letting fatigued workers inspect, test, and repair safety equipment.

## Susquehanna Steam Electric Station Unit 2, PA

### THE NEAR-MISS

The NRC sent an SIT to the site after the Unit 2 reactor automatically shut down due to equipment problems. The equipment causing this unplanned shutdown had been causing problems for several weeks.

### HOW THE EVENT UNFOLDED

At 5:31 p.m. on December 19, 2012, the Unit 2 reactor at the Susquehanna nuclear plant in Pennsylvania automatically shut down due to decreasing water level inside the reactor

***Shearon Harris operated for nearly a year with a degraded condition that, when finally considered properly, resulted in the reactor being shut down within hours for safety reasons.***

vessel. Workers were in the process of restarting the reactor following its unplanned shutdown during a test three days earlier when this incident occurred with the unit operating at 18 percent power.

The Unit 2 reactor began commercial operation in February 1985. In June 2011, workers replaced the original analog system used to control the rate of makeup water flow to the reactor vessel with a digital system. This replacement mirrored activities occurring across the nuclear industry as original equipment wears out.

The Susquehanna nuclear plant features two boiling water reactors. Each reactor has three feedwater pumps that provide makeup water to the reactor vessel to compensate for the inventory leaving as steam. The feedwater control system can be operated in automatic or manual mode. In manual mode, the operators adjust pump speeds and valve positions to establish the desired makeup flow rate to the reactor vessel. In automatic mode, the control system monitors parameters like the water level inside the reactor vessel and the steam flow rate and sends electrical signals that change pump speeds and valve positions as necessary to regulate the makeup flow rate.

On December 19, the Unit 2 reactor's low power level during the startup did not require all three feedwater pumps to be running. Consequently, pump A was running, pump B was in standby, and pump C was off.

At 5:09 pm, an operator placed the feedwater control system in automatic mode. That action was expected to result in the valve regulating flow through the pump to open slightly, but the valve remained closed. A check revealed that this valve had a two-year history of sticking in the closed position.

<sup>9</sup> For example, see NRC Regulatory Guide 1.8, *Qualification and Training of Personnel for Nuclear Power Plants*, online at <http://pbadupws.nrc.gov/docs/ML0037/ML003706932.pdf>.



© U.S. Nuclear Regulatory Commission

*Reactor operators using unapproved procedures led to problems at the Susquehanna plant in Pennsylvania.*

The operators developed a contingency plan. They would open the electrical breaker to the motor-operated valve and crank the valve slightly open using a local handwheel.

An operator opened the electrical breaker at 5:30 p.m. The control system, still in automatic mode, lost its input signal for this valve when the breaker opened. By design, the control system interpreted the loss of signal to mean that the valve was fully open. The system responded to that presumed condition by sending signals to close other feedwater system valves to compensate for the wide-open valve.

Operating at 18 percent power, the Unit 2 reactor continued to produce a considerable amount of steam that went to the turbine/generator to make electricity. But with all three feedwater system valves closed, that inventory loss was no longer being matched by makeup flow. The operators quickly attempted to place feedwater pump B in service, but the control system, being in automatic mode, blocked their efforts. In less than two minutes, the water level inside the reactor vessel dropped to the point where an automatic shutdown was signaled. The control rods were rapidly inserted within seconds to stop the nuclear chain reaction.

The potential for a loss of power to one feedwater system valve tricking the control system in automatic mode into closing all feedwater system valves had been identified in January 2010. But this vulnerability was accepted as-is on the basis that the operators would instinctively respond by placing

the old analog control system into manual mode and taking whatever recovery steps were necessary.

The new digital control system, however, experienced several problems after being installed in June 2011. For example, during a reactor startup on August 23, 2011, operators were unable to open the valve for feedwater pump A. They opened the electrical breaker to the motor-operated valve and hand-cranked it open slightly. The subject matter expert for the flow control system determined from this event that the system had to be placed in manual mode before opening the electrical breaker to prevent the system from falsely thinking the valve was fully open. But this awareness was not translated into operating procedures for the new digital system or into training for the operators on how to use it.

On August 25, 2011, workers labeled the problem with the valve for feedwater pump A sticking in the closed position as an Operator Burden.<sup>10</sup> But contrary to the Operator Burden procedure, no guidance was provided or compensatory actions taken to help the operators successfully handle that identified burden in the future.

On October 18, 2012, workers developed a maintenance package to repair the troublesome valve during an outage planned the following month. But the maintenance was not performed during the outage.

Just-in-time training (JITT) was performed on December 17, 2012, for the upcoming Unit 2 reactor startup. JITT is standard industry practice for reacquainting workers with tasks that are not routinely performed. However, only three of the eight operators scheduled to work during the Unit 2 reactor startup attended the training; even if they had, the training did not adequately cover how to use the new feedwater control system during startups (Miller 2013).

#### **NRC SANCTIONS**

The SIT identified one violation in the initiating events cornerstone and two violations in the mitigating systems cornerstone:

- Failure to develop and use approved procedures for operating plant equipment. When approved procedures failed to obtain the desired feedwater flow rate during the Unit 2 startup on December 19, 2012, the operators attempted informal, unapproved steps to get the system to respond.
- Failure to develop adequate procedures and associated training for the operators to properly respond when the

<sup>10</sup> In the mid- to late 1990s, the NRC and the nuclear industry placed considerable emphasis on identifying and removing conditions that set operators up to fail. For example, improper set points that generated alarms in the control room even though equipment was performing acceptably distracted operators and tempted them to later ignore valid alarms. Such conditions were termed Operator Burdens at this facility.

control system in automatic mode causes the feedwater system valves to close.

- Failure to enter the problem identified in August 2011—that a loss of power to a feedwater system valve would cause the control system in automatic mode to close other feedwater system valves—into the plant’s corrective action program.

All these violations were classified as Green (Miller 2013).

#### UCS PERSPECTIVE

This near-miss illustrates the exact dilemma posed by the bathtub curve long familiar to reliability engineers (Figure 4). The bathtub curve shows the risk of failure over time. In the low, flat middle of the curve, the failure risk is lowest. On the right-hand side, the failure rate increases as parts wear out. On the left-hand side, the failure rate is initially high due to material imperfections, assembly errors, operator training, and other factors during the break-in or “infant mortality” phase.

The original feedwater control system at Susquehanna was heading toward, if not already in, the wear-out portion of the bathtub curve where the chance of failure increases. Its owner sought to properly manage the risk by replacing the aging system with a start-of-the-art digital one.

The new system, however, cannot skip directly to the flat, middle portion of the bathtub curve. Instead, the

peculiarities of the new system have to be learned by trial and error during the break-in phase.

This near-miss reminds us of the relative value of good intentions versus good deeds. The digital control system was determined to be vulnerable to a power failure when in automatic mode—but this liability was dismissed on the basis of good intentions about proper operator responses without the good deeds of adequate procedures and training. One feedwater valve experienced recurring problems sticking closed—but that chronic problem was “remedied” by the good intentions of repairing it during the November 2012 outage without the good deed of actually doing the repairs.

***This near-miss illustrates the exact dilemma posed by the bathtub curve long familiar to reliability engineers.***

The December 2012 startup of the Unit 2 reactor was an infrequently performed activity—but that challenge was addressed with the good intention of just-in-time-training without having all the operators attend the training. And the operators who attended the class were not given

FIGURE 4. The Bathtub Curve

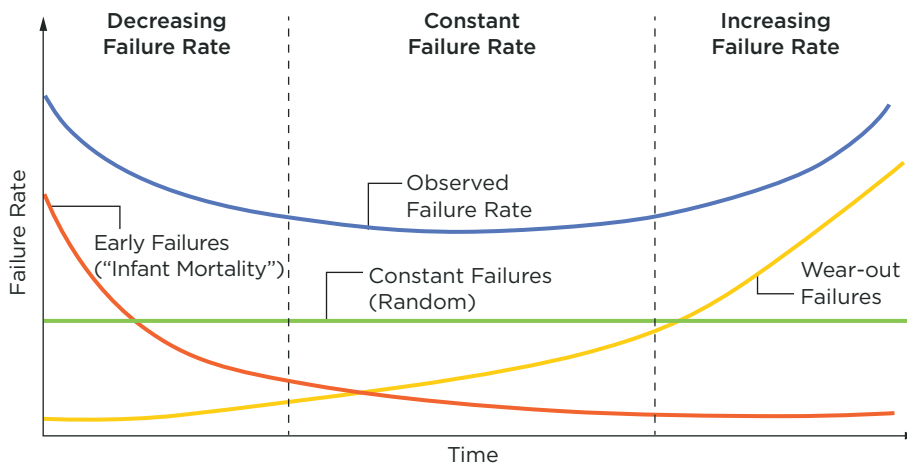

*The bathtub curve illustrating the chance of failure (vertical axis) over a product’s lifetime (horizontal axis).*

SOURCE: THOMPSON 2013.

information about the new digital feedwater control system during startups.

At a nuclear plant, substituting good intentions for good deeds can precipitate disaster.

### Observations on the Near-Misses in 2013

The near-miss at Arkansas Nuclear One was unfortunately not a near-miss for the one worker who died and the other workers who were injured. The nuclear industry has a good industrial safety track record. This tragedy reminds us all why that effort and focus is necessary.

The onsite response to the Arkansas Nuclear One near-miss was very commendable. Workers faced numerous challenges far from routine and ordinary. They diagnosed the situations correctly and took proper actions to mitigate problems and stabilize conditions as promptly as possible. The majority of lessons-learned campaigns probe disasters to identify wrong steps that should never be taken again. This event deserves examination to identify the right steps that *should* be taken again.

For the first year since 2010, none of the other near-misses resulted in greater-than-green sanctions by the NRC.

In other words, the significance of the near-misses in 2013 was lower than in the three prior years. This is a step in the right direction and UCS hopes it will be followed by additional steps in the future.

Summarizing the lessons learned from the near-misses in 2013 described more fully in the chapter above:

- The NRC and the nuclear industry should study the Arkansas Nuclear One near-miss to identify and institutionalize the elements contributing to the successful response.
- The NRC should periodically re-inspect fixes to safety problems, such as those mandated by the agency's generic communications program, to determine whether they continue to be effective.<sup>11</sup>
- The NRC should revise its license renewal process to provide assurance that reactors are operating consistent with applicable regulatory requirements.
- The NRC and the nuclear industry should protect against human performance impairment caused by fatigue all the time, not just when reactors are operating.

---

<sup>11</sup> The NRC's generic communications include Information Notices, Bulletins, and Generic Letters. See <http://www.nrc.gov/reading-rm/doc-collections/gen-comm/bulletins> to access additional information about bulletins issued to plant owners by the NRC about safety problems and their mandated fixes.

## Trends from Near-Misses 2010–2013

This chapter describes our analysis of the data from the nuclear reactor near-misses reported in our four annual reports covering the years 2010 to 2013.

As presented in Table 3 (p. 28), 70 near-misses were reported at 48 different reactors over this period. The number of reactors experiencing near-misses decreased from 29 in 2010 and 2011 and 18 in 2012 to 14 in 2013. As noted above in the “Observations on the Near-Misses” section of Chapter 2, there was also a marked reduction in the significance of near-misses in 2013 compared with the prior three years. The decrease in number of reactors experiencing near-misses coupled with a lessening of the severity of such events is encouraging. While one data point (a significant drop in near-misses in 2013) does not constitute a trend, it is nonetheless a move in the right direction that hopefully will be sustained in future years.

The Wolf Creek Generating Station in Burlington, Kansas, broke its record streak of three straight years with at least one NRC special inspection. An old English proverb says that “all good things must come to an end.” Apparently, so too must bad things.

On the other hand, the NRC conducted three special inspections at the Columbia Generating Station in 2013—two for security matters and one for a safety problem. It is the first time in this series of reports that any reactor chalked up more than two special inspections in a single year. Like golf, nuclear safety and security is won by a low score on this NRC inspection tally. Time will tell whether the trio of near-misses at the Columbia Generating Station was merely bad luck or indicative of broader programmatic deficiencies.

***Time will tell whether the trio of near-misses at the Columbia Generating Station was merely bad luck or indicative of broader programmatic deficiencies.***

More than half of the nation’s reactors did not experience a near-miss between 2010 and 2013. If performance during this period by the other half is representative of overall industry performance, however, then it may only be a handful of years before near-misses occur at those reactors as well.

In particular, the 2010–2013 data indicate that the “average” reactor has a roughly one-in-six chance each year that it will experience a near-miss. With reactors originally licensed for 40 years and most being relicensed for an additional 20 years, that rate—if sustained—means the typical reactor could experience seven near-misses over its 40-year lifetime and 10 near-misses over 60 years.

While none of the 70 near-misses over the past four years harmed the general public (as opposed to workers), the “safety pyramid” provides ample reason to reduce their occurrence. Introduced by H. W. Heinrich in his 1931 book

*Industrial Accident Prevention*, the safety pyramid explains the relationship between the number of accidents and their severity levels.<sup>12</sup> As suggested by its name, the larger the base of minor accidents, the more often major accidents will occur. By reducing the situations and behaviors that lead to near-misses, one reduces the number of serious accidents, too.

While both the number and severity of near-misses dropped in 2013 compared with events from 2010 to 2012,

it is far from time to declare victory and reallocate resources and attention elsewhere. Positive outcomes reinforce the need for the efforts that achieved them rather than suggest the efforts have served their purpose and can be trimmed or eliminated. If anything, once movement in the right direction is verified, it's time to step on the accelerator instead of letting up or applying the brakes.

TABLE 3. Near-Misses 2010–2013

	Reactors	Total Number of Near-Misses	Near-Misses in 2010	Near-Misses in 2011	Near-Misses in 2012	Near-Misses in 2013
1	Arkansas Nuclear One Unit 1	2	1			1
2	Arkansas Nuclear One Unit 2	2	1			1
3	Braidwood Unit 1	2	1	1		
4	Braidwood Unit 2	2	1	1		
5	Browns Ferry Unit 1	1				1
6	Browns Ferry Unit 2	1				1
7	Browns Ferry Unit 3	1				1
8	Brunswick Unit 1	1	1			
9	Brunswick Unit 2	2	1		1	
10	Byron Unit 1	1		1		
11	Byron Unit 2	2		1	1	
12	Callaway	1		1		
13	Calvert Cliffs Unit 1	1	1			
14	Calvert Cliffs Unit 2	1	1			
15	Catawba Unit 1	2	1		1	
16	Catawba Unit 2	1	1			
17	Columbia	3				3
18	Cooper	1		1		
19	Crystal River Unit 3	1	1			
20	Davis-Besse	1	1			
21	Diablo Canyon Unit 2	1	1			
22	Farley Unit 1	1			1	
23	Farley Unit 2	2	1		1	
24	Fort Calhoun	4	1		2	1
25	H.B. Robinson	2	2			
26	LaSalle Unit 1	1				1
27	LaSalle Unit 2	1				1
28	Millstone Unit 2	1		1		

<sup>12</sup> See [http://www.skybrary.aero/index.php/Heinrich\\_Pyramid](http://www.skybrary.aero/index.php/Heinrich_Pyramid).

*While both the number and severity of near-misses dropped in 2013 compared with events from 2010 to 2012, it is far from time to declare victory and reallocate resources and attention elsewhere.*

TABLE 3. Near-Misses 2010–2013 (continued)

	Reactors	Total Number of Near-Misses	Near-Misses in 2010	Near -Misses in 2011	Near-Misses in 2012	Near-Misses in 2013
29	North Anna Unit 1	1		1		
30	North Anna Unit 2	1		1		
31	Oconee Unit 1	1		1		
32	Oconee Unit 2	1		1		
33	Oconee Unit 3	1		1		
34	Oyster Creek	1				1
35	Palisades	3		2	1	
36	Palo Verde Unit 1	1			1	
37	Palo Verde Unit 2	1			1	
38	Palo Verde Unit 3	1			1	
39	Perry	2		1	1	
40	Pilgrim	2		2		
41	River Bend	1			1	
42	San Onofre Unit 2	1			1	
43	San Onofre Unit 3	1			1	
44	Shearon Harris	2			1	1
45	Surry Unit 1	1	1			
46	Susquehanna Unit 2	1				1
47	Turkey Point Unit 3	1		1		
48	Wolf Creek	4	1	1	2	
	<b>Total</b>	70	19	19	18	14

## Positive Outcomes from NRC Oversight

This chapter describes situations in 2013 where the NRC acted to bolster nuclear safety. These positive outcomes are not necessarily the best the NRC achieved last year—we would have had to review and rate all NRC efforts to make that claim. Nor are these outcomes the only positive ones the NRC achieved last year—far from it. Instead, we chose situations with good outcomes that show the NRC can be an effective regulator and provide insights into how the agency can emulate these commendable outcomes more consistently.

### Connecting the Dots on Component Aging

The NRC reviewed 105 reports about age-related failures of important components at nuclear power plants between 2007 and 2011. The NRC found that in more than 75 percent of the failures, the components had either been operated longer than the service life recommended by the manufacturer or had been intentionally run until they failed (Thompson 2013).

As an example, a circuit board in the control system of a battery charger at the Calvert Cliffs Nuclear Power Plant in Lusby, Maryland, overheated and failed. The vendor recommended replacing the electrolytic capacitors in this type of circuit board every 10 years because age-related degradation increased the likelihood of failure. The circuit board at Calvert Cliffs failed after being in service longer than 16 years.

The report noted that age-related degradation failures will tend to increase as more reactors operate past their original 40-year licensed lifetimes into the 20-year license renewal periods.

The NRC went beyond merely looking at failure trends to also examine its associated regulatory oversight footprint.



*A failed circuit board at the Calvert Cliffs plant in Maryland illustrates one of the challenges of aging equipment.*

The NRC noted that Criterion III in Appendix B to 10 CFR Part 50 requires that plant owners formally evaluate the adequacy of leaving important components in service longer than their qualified lifetimes. The failures constituted *prima facie* evidence that this regulatory requirement had been violated. Yet the NRC noted that only seven violations had been cited for the dozens of age-related failures caused by operating important components longer than their vendor-recommended service lifetimes. The NRC's review concluded, "It is reasonable to question why NRC oversight programs are not more focused on aging management of active" components (Thompson 2013).



***In more than 75 percent of failures, components had either been operated longer than recommended or intentionally run until they failed.***

The NRC's Office of the Inspector General (OIG) followed up on the NRC's study by auditing the agency's oversight of component aging. OIG's audit concluded:

*NRC's approach for oversight of licensees' management of active component aging is not focused or coordinated. This has occurred because NRC has not conducted a systematic evaluation of program needs for overseeing licensees' aging management for active components since the establishment of the Reactor Oversight Process (ROP) in 2000, and does not have mechanisms for systematic and continual monitoring, collecting, and trending of age-related data for active components. Consequently, NRC cannot be fully assured that it is effectively overseeing licensees' management of aging active components. (OIG 2013)*

The positive outcome resulted from the agency's proactive identification of the need to better oversee aging management of active components. Rather than waiting for the postmortem following a nuclear reactor accident to reveal this shortcoming, the NRC reviewed failure data at its own initiative and identified areas for improvement. The OIG confirmed and reinforced these findings through its audit.

The NRC could still snatch defeat from the jaws of victory by failing to implement the recommendations from the review and audit, but based on discussions with NRC staff and managers, UCS has reason to believe these steps will be taken.

### **Putting Georgia on Probation**

Laws such as the Atomic Energy Act of 1954 give the NRC almost exclusive jurisdiction over the regulation of nuclear energy and nuclear materials. The NRC has formally delegated some of its authority to states under its Agreement State

program.<sup>13</sup> Georgia is one of the states authorized by the NRC to license and inspect certain nuclear materials.

The NRC placed Georgia on probation following its assessment that the state's program rated unsatisfactory in two areas and rated satisfactory but needing improvement in three other areas (Weber 2013). It was the first time the NRC ever placed a state's program on probation (Conley 2013).

While the NRC delegated authority for nuclear materials to Georgia and other states, it retained the responsibility to ensure that risks from these materials are properly managed. The NRC periodically evaluates how effectively the states are discharging their delegated authorities.

Georgia's probation demonstrates that the NRC has not placed blind faith in the states successfully carrying out their delegated authorities. The NRC made 11 recommendations to the state for improved performance and undertook steps to monitor progress. Thus, the NRC required more extensive remedies than merely having the poor report card signed by the governor of Georgia and returned. The problems reflected in the poor report card must be remedied before the state can get off probation.

The ripple effect will likely reap dividends as other NRC Agreement States undertake assessments to either confirm their programs do not share Georgia's shortcomings or identify areas to be upgraded before the NRC next evaluates their programs.

### **Allowing Fort Calhoun to Restart**

On December 17, 2013, the NRC authorized the Omaha Public Power District (OPPD) to restart its Fort Calhoun nuclear plant in Nebraska (Dapas 2013). The OPPD shut the plant down in April 2011 for a routine refueling outage. Unplanned events and discoveries, including the plant temporarily becoming an island when the Missouri River overflowed its banks in June 2011, extended the outage.

The positive outcome in this case is not that the NRC allowed the plant to be restarted—it is that the agency prevented the plant from operating until safety shortcomings had been resolved to its satisfaction.

The NRC issued a confirmatory action letter (CAL) to the OPPD on September 2, 2011. The CAL listed problems that the OPPD had to resolve before it could restart Fort Calhoun (Dapas 2013).

The OPPD submitted a report to the NRC on December 2, 2011, outlining the steps it would take to resolve the problems

<sup>13</sup> See <http://nrc-stp.ornl.gov/asdirectory.html> for additional information and a listing of current Agreement States.



© U.S. Army Corps of Engineers/Wikimedia

*Flooding of the Missouri River in June 2011 kept Nebraska's Fort Calhoun plant out of operation.*

identified in the CAL. The OPPD's action plan would clearly take considerable time to complete, so the NRC announced on December 13, 2011, that it was placing Fort Calhoun under the agency's Manual Chapter 0350 process (Dapas 2013).<sup>14</sup>

The NRC normally uses its Reactor Oversight Process as outlined in Chapter 1 to oversee nuclear plants. But the ROP collects and assesses performance results from operating reactors. The longer a reactor does not operate, the less applicable the ROP becomes. Therefore, the NRC invokes Manual Chapter 0350 to tailor an oversight regime for the specific problems at a plant in a prolonged outage.

The NRC typically holds one public meeting each year in the community around every nuclear plant. The NRC conducted several public meetings each year near Fort Calhoun to update the community on the situation at the plant.

The NRC issued another CAL to the OPPD on June 11, 2012, expanding the list of problems to be resolved. The NRC's new CAL also included a restart checklist of items to be addressed by the OPPD and verified by the NRC (Dapas 2013). Both the OPPD and the NRC used this checklist along the road to restart.

The OPPD notified the NRC when it felt it had successfully resolved items on the NRC's CALs and checklist. The NRC dispatched inspectors to the plant to examine the completed work and determine whether it was satisfactory. The NRC documented these inspections and their results in numerous publicly available reports (Dapas 2013).

After verifying that all the items on the CALs and checklist had been resolved, the NRC authorized the OPPD to restart Fort Calhoun (Dapas 2013).

This Fort Calhoun case reflects well on the NRC. The NRC established clear, objective safety criteria in its ROP. When performance levels at Fort Calhoun fell below those defined safety levels, the NRC did not allow the OPPD to restart the reactor until the shortcomings were rectified. Thus, the NRC did not apply ad hoc protocols to keep Fort Calhoun from operating.

Likewise, the NRC did not apply ad hoc protocols when allowing the OPPD to restart Fort Calhoun. Instead, it laid out a clear "to do" list and monitored the OPPD's efforts in completing those items. The company, and the public, could see the goal posts and progress toward them.

<sup>14</sup> See <http://pbadupws.nrc.gov/docs/ML0634/ML063400076.pdf> for additional details about Manual Chapter 0350.

## Not Doing What It Said It Would Do

The NRC began using its Reactor Oversight Process to evaluate safety performance at the nation's nuclear power plants in 2000.<sup>15</sup> The ROP consists of inspection, assessment, and enforcement elements. The inspection effort includes a number of specific examinations to be conducted at each nuclear plant every year. The assessment effort provides for objective grading of the results from inspections. And the enforcement effort includes heightened NRC oversight activities when declining performance is identified.

During 2013, the NRC did *not* complete all the annual inspections promised under the ROP. And the NRC did *not* respond to declining performance signs as dictated by the ROP. How can the NRC not doing what it said it would do result in a positive outcome? In each case, the NRC formally provided solid reasons for not doing it.

In January 2013, the inspection and assessment results for the Perry Nuclear Power Plant in Perry, Ohio, called for it to be placed in the fourth column of the ROP's action matrix. Problems had been identified in the areas of radiation protection of workers and nuclear plant security. But NRC Region III opted to instead place Perry in the third column where the agency's mandated responses were smaller in depth and breadth (Mitlyng and Chandrathil 2013). The NRC evaluated the problems and concluded they did not reflect underlying programmatic weaknesses (Casto 2013). The ROP assumed that problems identified in different areas might have a common cause, such as insufficient budgets or ineffective management oversight. The ROP responded to this potential by sending in additional inspectors to determine whether disparate problems had the same contributing causes. But in this case, the NRC possessed sufficient information about the specific problems and their causes to establish that they had separate causes. Consequently, the agency decided not to place Perry into the fourth column of the action matrix. The ROP was designed to handle the majority, but not the entirety, of situations that can arise. Departing from the ROP's plan in this case was one of those exceptions and was well justified.

In November 2013, the NRC announced that ROP inspections scheduled to be conducted at the South Texas Project near Bay City, Texas, and at the Palo Verde Nuclear Generating Station in Wintersburg, Arizona, would not be performed. Instead, both would be deferred until 2014 (Kennedy 2013). Each of these deferrals involved what the NRC terms a component design basis inspection. Such inspections are among the most resource-intensive efforts undertaken by the NRC through routine ROP efforts. These

***How can the NRC not doing what it said it would do result in a positive outcome? It had solid reasons for not doing it.***

inspections consider a number of high-risk components and operator actions and evaluate how effectively they are handled within applicable training, maintenance, engineering, and testing programs. The NRC justified deferring these two inspections because of the federal government shutdown in October 2013. The NRC supplements its own inspection staff on component design basis inspections with experts from national laboratories. The federal government shutdown made it impossible to reschedule qualified teams before the end of 2013, so the inspections were deferred until early 2014. As in the Perry case, these deferrals entailed formal justification of the ROP element that was not being fulfilled as advertised. Also as in the Perry case, the departure from the ROP's plan was warranted.

"Plan your work and work your plan" speaks to the value of thinking ahead and thinking en route to positive outcomes. But few plans, no matter how carefully developed, cover every possible contingency. At Perry and later at the South Texas Project and Palo Verde, the NRC's ROP plan



*Inspections at the Perry plant in Ohio illustrate a successful oversight process.*

© U.S. Nuclear Regulatory Commission

<sup>15</sup> See <http://www.nrc.gov/NRR/OVERSIGHT/ASSESS/index.html> for additional information.

specified that certain measures be taken. But the NRC did not take these steps only after formally determining—and documenting—solid reasons why circumstances warranted otherwise. The NRC planned its work and justified mid-course corrections while working its plan.

### **Observations on Effective NRC Oversight**

The “Connecting the Dots on Component Aging” section above describes how the NRC reviewed operating experience and determined that regulatory requirements provide adequate protection against safety margins being compromised by age-related degradation. Despite verifying that the safety bar was set at the proper height, the NRC’s review found that too often owners fell short of that bar. This is a commendable example of the NRC proactively identifying a problem at an early stage to allow remedies to be applied before it grows to epidemic proportions.

The Georgia and Fort Calhoun examples illustrate the NRC being a fair and effective regulator. In both cases, the

NRC objectively identified sub-par performance against clear and pre-existing standards. Rather than writing tickets for large fines that empty wallets without resolving problems, the NRC provided explicit road maps intended to restore performance levels. And the NRC defined the monitoring it would do to guard against detours along the paths to its desired destinations.

The two examples of the NRC not doing what it said it would do also illustrate the NRC being a fair and effective regulator. In both cases, the NRC had solid, unassailable justification for deviating from its plans. And the NRC made these justifications public to prevent anyone from ascribing untoward motives for the deviations. As these examples demonstrate, being an effective regulator does not mean rigidly adhering to plans—it involves relentlessly striving for the goals and objectives the plans seek.

Proactively looking to see whether expectations are being achieved, holding people accountable for shortcomings, facilitating solutions, and making prudent mid-course corrections are commendable attributes deserving recognition.

## Negative Outcomes from NRC Oversight

This chapter describes situations that arose or were revealed in 2013 in which lack of effective oversight by the NRC led to negative outcomes. These outcomes are not necessarily the worst the NRC achieved last year. Rather, they shed light on practices and patterns that prevent the NRC from achieving the return it should from its oversight investment.

Chapter 4 above provided positive outcomes achieved by the NRC last year—an abridged listing demonstrating that the NRC is not an incompetent regulator. The abridged listing in this chapter demonstrates, however, that the NRC has some consistency issues to work through.

### Mismanaging the Spent Fuel Pool Risk

In response to the tragedy at Fukushima, the NRC formed a task force to review the accident and recommend measures to better manage nuclear power risks in the United States. The task force made nearly three dozen recommendations (NTTF 2011).

NRC senior managers reviewed the panel’s report and submitted an action plan to the NRC’s chairman and commissioners on how to prioritize and implement the recommendations. The NRC’s senior managers also added six additional recommendations to the task force’s list based on concerns expressed by external stakeholders (Borchardt 2011). The public and public-interest organizations, including UCS, championed one of these additional recommendations: namely, the one calling for accelerating the transfer of irradiated fuel from spent fuel pools to dry casks.

The NRC conducted literally hundreds of public meetings during 2012. As shown by Figure 5, 82 of these meetings

focused on the agency’s efforts to implement lessons learned from Fukushima. The NRC’s stated purpose for these meetings was “to explain how we’re implementing lessons learned from Fukushima and to include the public in our decision-making process.” The notices and agendas reveal that *none* of these 82 public meetings substantively covered the spent fuel transfer recommendation that the public had put on the table.

The NRC issued its spent fuel pool scoping study in June 2013 (Barto et al. 2013). The NRC conducted its first public meeting on the spent fuel transfer recommendation on August 22, two months *after* the agency issued its study concluding that there was no need to change current spent fuel storage practices.

It is totally inexcusable that an agency proclaiming to be open and transparent would prevent meaningful public interaction regarding an issue put forth by the public.

FIGURE 5. Fukushima Public Meetings



*NRC infographic showing the number of public meetings conducted by the NRC during 2013 about lessons it learned from the accident at Fukushima.*

SOURCE: [WWW.NRC.GOV](http://WWW.NRC.GOV)



After about five years in a cooling pool, spent reactor fuel can be transferred to dry casks like these, which do not need electric power to keep the fuel from overheating.

Due to the federal government's failure to open a repository for spent fuel, virtually all the spent fuel produced by operating nuclear power reactors remains at the plant sites. This is true even for reactors that were permanently shut down years ago, and have had their reactor vessels packaged, transported, and buried in licensed radioactive waste dumps.

When spent fuel assemblies are initially discharged from reactor cores, the decay of short-lived fission by-products emits significant amounts of radiation and heat energy. Spent fuel assemblies are placed into metal storage racks in the bottom third of large swimming-pool-like structures. The water in these spent fuel pools is continuously cooled to remove heat being emitted by the spent fuel assemblies. The water also functions as a shield to drastically attenuate radiation levels, allowing workers to perform tasks in the area without undue risk.

After five years, radioactive decay of fission by-products within spent fuel assemblies has lowered the heat and radioactivity emissions to the point that assemblies can be transferred from the pools into dry storage. Workers lower a large metal canister into the spent fuel pool, transfer 24 to 56 spent fuel assemblies into it, lift the loaded canister out of the pool, drain water from the canister and replace it with an inert gas

like nitrogen, seal a lid onto the canister, and place the canister inside a concrete vault or cask on the plant site.

Dry storage involves no moving parts. Decay heat conducted through the metal walls of the canister is removed by natural convection—the chimney effect of air flowing through a gap between the canister and its protective concrete enclosure. Air cooling alone maintains the temperature of the metal fuel rods at or below the temperature experienced when the fuel assemblies were inside the reactor core of an operating plant.

Standard industry practice has been to wait until the storage racks in spent fuel pools are nearly filled and then transfer spent fuel assemblies into dry storage only as needed to free up space for the assemblies being discharged during the next refueling outage.

The public and public-interest organizations, including UCS, advocate accelerating the transfers into dry storage. Instead of maintaining the spent fuel pools near full capacity, this alternative reduces the inventory down closer to only those assemblies discharged within the past five years. Rather than having spent fuel pools containing 6 to 10 times as many assemblies as reside in their reactor cores during operation, this alternative reduces the inventory to one to two cores' worth.

***Standard industry practice has been to wait until the storage racks in spent fuel pools are nearly filled and then transfer spent fuel assemblies into dry storage only as needed to free up space.***

FIGURE 6A. Risk from Spent Fuel Pool Storage

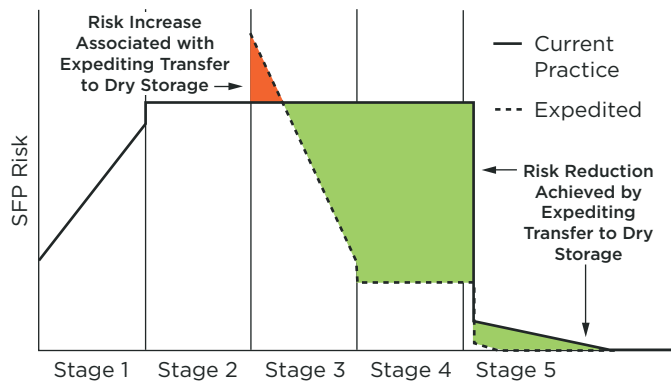
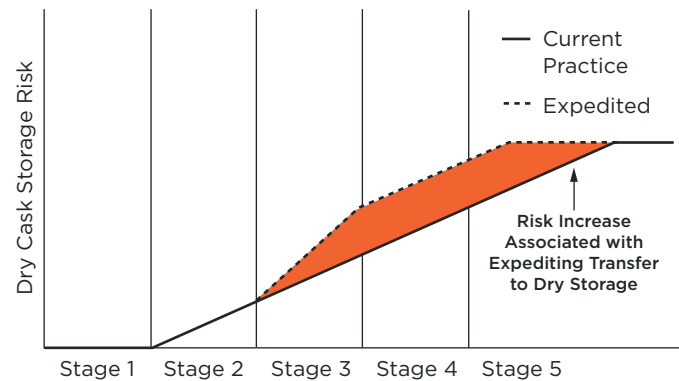

FIGURE 6B. Risk from Dry Storage



Irradiated fuel assemblies are only stored in spent fuel pools in stage 1. As a spent fuel pool becomes nearly filled, fuel assemblies begin to be transferred into dry storage in stage 2. During stage 3, irradiated fuel assemblies get transferred into dry storage not only when needed to create space for the next batch discharged from the reactor core but also to reduce the spent fuel pool inventory to a minimal amount (roughly the equivalent of one to two reactor cores). Fuel assemblies continue to be transferred into dry storage during stage 4 to maintain the spent fuel pool's inventory near a minimal amount. The reactor is permanently shut down during stage 5 and all fuel assemblies get transferred into dry storage. The orange areas represent higher risks caused by the accelerated or expedited transfer option compared with the current industry practice. The green areas represent lower risks associated with the expedited transfer option relative to the current industry practice.

NOTE: The NRC assumes that terrorist and sabotage risks are zero for both storage methods.

SOURCE: BARTO 2013.

The benefits noted by advocates of this alternative include reducing the amount of decay heat in the spent fuel pool. If cooling is interrupted or water drains from the spent fuel pool, lowered decay heat levels provide workers more time to restart the cooling system or restore the water level (and thus with greater odds of success). Additionally, having fewer spent fuel assemblies in the storage racks means that if an accident cannot be avoided, the amount of fuel damaged and the amount of radioactivity released to the environment will be much smaller. Thus, both the probability and consequences of spent fuel pool accidents are lessened by thinning their storage inventories.

To be sure, dry storage is not risk-free. If it were, the repository issue would shrink to a more manageable task of deciding where to put all the invulnerable canisters.

The risks from dry storage include the safety risk associated with moving canisters into and out of spent fuel pools and the security risk of canisters in dry storage. Each canister weighs nearly 80 tons unloaded and around 100 tons when loaded with spent fuel assemblies. (Recall that the near-miss summarized in Chapter 2 was caused by a heavy load being dropped at Arkansas Nuclear One.) If a crane lifting a canister into or out of a spent fuel pool drops its cargo, the dropped canister could cause the wall or floor of a spent fuel pool to break and its water to leak out. Canisters inside dry storage in

open areas—particularly at permanently shut-down reactors where security and other infrastructure has been significantly reduced—could be tempting targets for saboteurs and terrorists.

An important issue is whether the risks outweigh the benefits of spent fuel transfers. For example, current practices allow workers to fully load each canister with a mixture of “old” spent fuel (i.e., assemblies discharged from the reactor core two decades ago) and “new” spent fuel (i.e., assemblies discharged from the reactor little more than five years ago). Accelerated transfers might eventually eliminate the stock of old spent fuel, leaving only new spent fuel. The amount of decay heat emitted by spent fuel assemblies loaded into a canister is limited. (The chimney is a fixed size and can only carry away so much heat via natural convection.) To stay within the decay heat limit, workers may have to reduce the number of spent fuel assemblies placed in canisters. If so, more canisters would be needed to contain the same number of spent fuel assemblies, driving up the costs as well as increasing the chance that a canister someday gets dropped.

The NRC's study included Figures 6A and 6B, which show the relative risk profiles from storing irradiated fuel assemblies in spent fuel pools and in dry storage. These figures also reflect the change in the risk profiles if the current practice is revised to accelerate or expedite transfer into dry storage. But the NRC's study did not define the magnitude or

duration of the risks—in other words, it did not show whether the potential risk reductions (i.e., the areas shown in green) are smaller than, equal to, or larger than the potential risk increases (i.e., the areas shown in orange). Those insights are necessary to make an informed decision about whether accelerated transfer of irradiated fuel assemblies from spent fuel pools into dry storage reduces risk, and, if so, under what conditions.

The NRC should have engaged the public during development of its spent fuel pool consequences study (Barto 2013) and should have addressed the relative risks from storing irradiated fuel assemblies in spent fuel pools and dry storage under current practices and the proposed accelerated transfer option. The NRC did not serve the public or nuclear safety well by failing on both accounts.

### Conspiring to Delay Safety Fixes at Oconee

The Fukushima tragedy resulted from one hazard (tsunami floodwater) that disabled the power supplies for emergency equipment after another hazard (earthquake) had taken away the normal power supplies. Large numbers of pumps and motors were literally powerless to prevent three reactor core meltdowns.

Fire poses a similar hazard in that it too can damage all the power supplies, rendering scads of safety components throughout the plant impotent. The NRC reported that, “Approximately one-half of the core damage risk at operating

reactors results from accident sequences that initiate with fire events” (NRC 2008). The fire risk roughly equals the risk from all other causes—including flooding—combined.

A fire in March 1975 at the Browns Ferry nuclear plant in Alabama demonstrated that hazard. A fire in the room directly beneath the control room for the Unit 1 and 2 reactors damaged electrical cables that powered and controlled emergency equipment throughout the plant. It was like a spinal injury that paralyzed the body by disrupting signals from the brain. Workers prevented dual meltdowns that day through heroic actions.

The NRC adopted fire protection regulations in 1980 intended to lessen the chances that another fire like that at Browns Ferry, or one even worse, could occur. These regulations require electrical cables for a safety system to be separated from the electrical cables for its backup, to minimize the chances that both would be damaged by a single fire. The regulations also mandated upgrades to fire detection and suppression systems to minimize the chances that a single fire could grow large enough to damage the separated cables.

Nearly two decades later, the NRC discovered that nearly half the reactors operating in the United States did not comply with the 1980 fire protection regulations. As a result, the owners of these reactors were allowing the possibility that a single fire could damage electrical cables for safety systems and their backups, and were relying on workers manually starting pumps, closing valves, and taking whatever other actions that undamaged cables would have enabled. Yet, the 1980 NRC regulations forbid reliance on manual actions

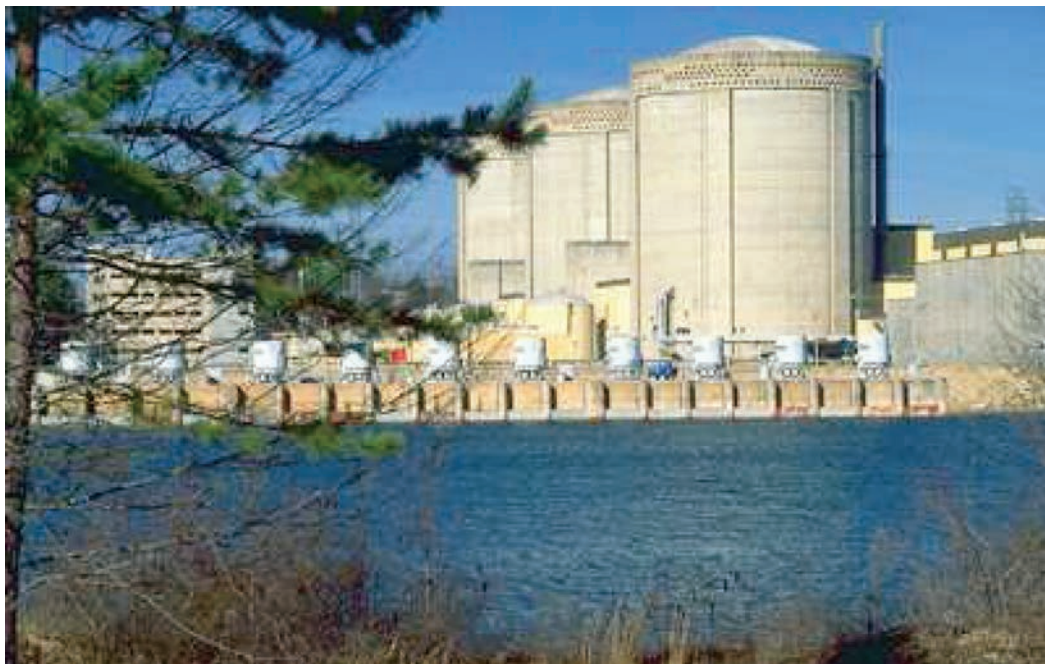

© U.S. Nuclear Regulatory Commission

*The Oconee plant in South Carolina is one of the U.S. reactors that does not comply with NRC fire regulations.*



unless the NRC had formally approved them after determining there would be sufficient staffing and capabilities to ensure the necessary steps could be taken within appropriate time frames.

In 2004, the NRC revised its fire protection regulations to provide owners with two options for managing fire risk: (1) comply with the 1980 regulations or (2) comply with new regulations that permitted manual actions when specific conditions were met.

The owner of the Oconee nuclear plant in South Carolina notified the NRC in 2005 of its intention to transition from non-compliance with the 1980 fire protection regulations to compliance with the 2004 regulations. The owner submitted an application to the NRC in 2008 defining the steps planned to achieve compliance. The NRC approved the company's plan in April 2010 and required that the owner complete all the steps by December 31, 2012.

In July 2012, the owner wrote to the NRC asking that the original deadline be extended by two years until December 31, 2014. Four months later, during a phone call with the NRC staff in November 2012, a company representative announced that additional delays would push the target deadline back yet another year to December 31, 2015 (Wright 2013).

On January 15, 2013, the NRC denied the owner's request for a two-year extension. The NRC denied the request because the risk was too large to allow continued reactor operation without the safety upgrades:

*The increase in core damage frequency (CDF) resulting from the change requested in the July 2012 application is about four times the greatest acceptable increase in CDF for a facility with a very low total risk, and 40 times the greatest acceptable CDF increase for a high total risk plant. This significant increase in CDF warrants the denial of the application based on the guidance of RG [regulatory guide] 1.174. (Evans 2013)*

After denying a request for a two-year extension because that would be too dangerous, the NRC ordered the owner on July 1, 2013, to complete the safety upgrades no later than November 15, 2016—nearly two years longer than the two-year extension request (Zimmerman 2013).

Thus, the three reactors at Oconee have operated at undue and elevated fire risk since 1980, when the NRC first adopted fire protection regulations. In other words, for more than three decades, Oconee's reactors have never met those fire protection regulations. If they had, there would have been no need to transition to the 2004 regulations. The

## ***The NRC discovered that nearly half the reactors operating in the United States did not comply with the 1980 fire protection regulations.***

NRC approved the owner's plan to finally manage the fire risk and set a December 31, 2012, deadline. The reactors' owners neither complied with the 1980 regulations nor with the 2004 regulations. Yet the NRC responded to the company's request for two more years by denying it for safety reasons and then ordering them to take up to nearly four years to try it.

What's protecting the people around Oconee from fire risk? Luck. What's protecting Oconee's owner from the cost and bother of legally managing the fire risk? The NRC.

Congress must take steps to ensure the NRC enforces its own regulations.

### **Allowing Diablo Canyon to Operate**

As described in Chapter 4, the NRC achieved a positive outcome in 2013 by allowing the Fort Calhoun reactor to restart only after ensuring that its known safety shortcomings had been corrected. Sadly, applause for that commendable outcome is muted by the NRC allowing the Diablo Canyon Power Plant at Avila Beach, California (about 12 miles southwest of San Luis Obispo) to operate despite known seismic safety shortcomings.

In 2008, an earthquake fault line was discovered in the seabed close offshore from the two Diablo Canyon nuclear reactors. An earthquake on this fault line could cause ground motions greater than the plant was designed to withstand. The NRC inspector assigned full-time to Diablo Canyon concluded that Pacific Gas & Electric (PG&E) had not properly and thoroughly evaluated the new hazard, but his position was overruled by managers in NRC's Region IV offices who allowed both reactors at the plant to continue operating. Their decision was undermined by the agency's own calculation concluding there was a one-in-six chance that the site could experience a devastating earthquake during its lifetime (Lochbaum 2013).<sup>16</sup>

16 For additional information, see <http://allthingsnuclear.org/seismic-shift-the-nrc-and-diablo-canyon>.



*The NRC has not enforced seismic regulations at the Diablo Canyon plant in California as it has at other nuclear plants.*

PG&E submitted a license amendment request to the NRC in October 2011, seeking to make the results from evaluations it did in the 1970s (for earthquakes on what is known as the Hosgri fault) and in the 1980s (under its Long Term Seismic Program) become the seismic design basis for Diablo Canyon. These results essentially reflect the same hazard posed by the shoreline fault. The NRC’s approval of the company’s proposed amendment to the operating license would indicate that existing protective measures against earthquakes were adequate even for the new fault discovered in 2008.

But the NRC could not and did not approve. On February 13, 2012, NRC staffers met to discuss their review of the license amendment request. The meeting’s agenda covered the reasons why the agency could not approve the request:

- The license amendment request did not satisfy the provisions within the NRC’s Standard Review Plan for the Review of Safety Analysis Reports for Nuclear Power Plants.
- PG&E’s re-evaluation of the reactor coolant system—the reactor vessel, the pressurizer, the steam generators, the reactor coolant pumps, and connecting piping—for the forces caused by an earthquake on the shoreline fault had not been completed.
- PG&E had not submitted a probabilistic risk assessment for earthquake hazards at Diablo Canyon (Sebrosky 2012).

Thus, the license amendment request was unacceptable to the NRC because it was incomplete and its completed portions failed to conform with the NRC’s established criteria. Yet the NRC allows the reactors to continue operating.

In the past, similar shortcomings were found in the earthquake protection for reactors at Beaver Valley in Pennsylvania; West Valley and FitzPatrick in New York; Humboldt Bay, San Onofre, and the General Electric Test Reactor in California; Surry in Virginia; and Maine Yankee. The NRC did not permit those eight nuclear facilities to operate with the known protection vulnerabilities. And the NRC did not permit their owners to use the unacceptable methods and assumptions used by PG&E (Lochbaum 2013).

NRC’s Region IV oversees both Fort Calhoun and Diablo Canyon. Faced with similar safety shortcomings, the staff and managers in this NRC office kept Fort Calhoun shut down for over two years while Diablo Canyon kept operating. Absent random decision-making processes like flipping a coin or tossing a dart at a “yes/no” chart, such disparate treatment cannot be explained.

The NRC is not right when preventing a reactor from operating and wrong when allowing a reactor to operate. The NRC is right by allowing safe reactors to operate and by preventing unsafe reactors from operating. The NRC was right in not allowing Fort Calhoun, Beaver Valley, Maine Yankee, and the other facilities to operate until known safety shortcomings were corrected. The NRC is wrong to allow Diablo Canyon to operate despite known safety shortcomings.

## Improperly Hiding Information

In June 2010, the NRC issued an order requiring Duke Energy to take 15 steps to lessen the likelihood that the company's earth-and-rock-fill Jocassee Dam (about 20 miles up the Keowee River from the Oconee nuclear plant) could fail, and to take additional steps to lessen flooding vulnerabilities at Oconee in the event the dam fails (Reyes 2010).

Months of discussions about the flooding hazard between the NRC and Duke preceded the order. The discussions included formal correspondence (e.g., Giitter 2010) and email messages (e.g., Ferrante 2010). In April 2009, the deputy director of the NRC's Division of Risk Assessment wrote:

*No other potential initiating event at Oconee is as risk significant. The probability of core damage from a Jocassee Dam failure is three times higher than the sum total probability of core damage from all initiating events. Duke has acknowledged that, given a Jocassee Dam failure with subsequent site inundation, all three Oconee units will go to core damage; that is, given a dam failure, the conditional core damage probability (CCDP) is 1.0 [100 percent].* (Criscione 2012)

But the NRC withheld from the public this order and all correspondence between it and Duke regarding the potential for all three reactors melting down if the Jocassee Dam broke. The information remained hidden until investigative reporter

small-break LOCAs are also threats posed by cooling water inventory losses. But drainage rates would be less, yielding a greater chance of successful intervention because there is more time before meltdown occurs and less makeup flow is needed.

The NRC estimated that the Jocassee Dam was 100 times more likely to occur than a large-break LOCA. Yet, before licensing Oconee to operate, the NRC determined that an array of emergency core cooling systems and containment barriers adequately protected the public from the large-break LOCA threat. The NRC's operating license for Oconee's reactors includes limitations on how the reactors can continue operating with emergency pumps out of service or containment degraded. Typically, that time is limited to 72 hours. If the problem cannot be corrected within that time limit, the reactor must be shut down.

The NRC typed "NOT FOR PUBLIC RELEASE—SECURITY RELATED INFORMATION" across the top and bottom of every page in the documents it withheld from the public. In most cases, the NRC only crossed out these headers and footers and did not redact any information from the documents before releasing them. In other words, the documents simply did not contain security-related information—which can and should be protected from public disclosure—and the NRC improperly applied this classification to hide the documents from the public. Had the NRC possessed a valid reason for withholding the documents, the documents

***The NRC remained silent about the problem it ordered Duke in June 2010 to correct at Oconee: namely, that a Jocassee Dam failure would yield a 100 percent chance of all three reactors melting down.***

Paul Koberstein of the *Cascadia Times* obtained it in response to his request under the Freedom Of Information Act (FOIA; Koberstein 2012). Additional FOIA requests from Koberstein and others resulted in the NRC releasing dozens, if not hundreds, of documents in 2013.

The flooding hazard at Oconee is very real and very high. Figure 7 (p. 42) is the NRC's own assessment of the flooding risk relative to other hazards at Oconee. For example, a large-break loss of coolant accident (LOCA) involves the rupture of a large pipe connected to the reactor vessel, rapidly draining away cooling water. Unless the standby emergency pumps quickly start and refill the reactor vessel, the reactor core will be damaged by overheating. The medium-break and

either would not have been released in response to the FOIA requests or would only have been released with security-related information redacted.

That the Jocassee Dam information was improperly hidden by the NRC is further evidenced by similar flooding hazards at other nuclear plants that the NRC made public. The NRC publicly described flood protection shortcomings at the Fort Calhoun Station in Nebraska (Collins 2010), Watts Bar Nuclear Plant in Tennessee (McCree 2013), and Monticello Nuclear Generating Plant in Minnesota (Pederson 2013).

Like Oconee, Watts Bar operates within NRC Region II. As at Oconee, the NRC identified flood protection deficiencies

at Watts Bar involving upstream dam failures that it required to be remedied by measures intended to lower the chances of dam failures and to increase protection levels against flooding. Unlike at Oconee, the NRC publicly released information about the problems at Watts Bar.

The NRC conducted a public meeting in Seneca, South Carolina, on April 19, 2011, to update the community on the results of its oversight activities at Oconee during 2010. Several residents, reporters, and local officials attended this meeting (Bartley 2011). The NRC remained silent about the problem it ordered Duke in June 2010 to correct at Oconee: namely, that a Jocassee Dam failure would yield a 100 percent chance of all three reactors melting down (Criscione 2012).

At the time of this meeting, the NRC knew that the failure of the Jocassee Dam was 100 times more likely to happen than a large-break LOCA. The NRC knew that the floodwater from a Jocassee Dam failure would almost certainly cause all three reactors at Oconee to melt down, just as three reactors had melted down at Fukushima when flooded just a month earlier. The NRC knew that Oconee was protected against a large-break LOCA, but could not operate for many days if the protective equipment was unavailable. The NRC knew that the fixes it ordered in June 2010 to properly protect Oconee from flooding had not all been implemented. The NRC knew that Oconee’s reactors continued operating despite this high and unmitigated risk. Yet the NRC withheld that knowledge

FIGURE 7. Risk of Core Damage at Oconee from Various Threats

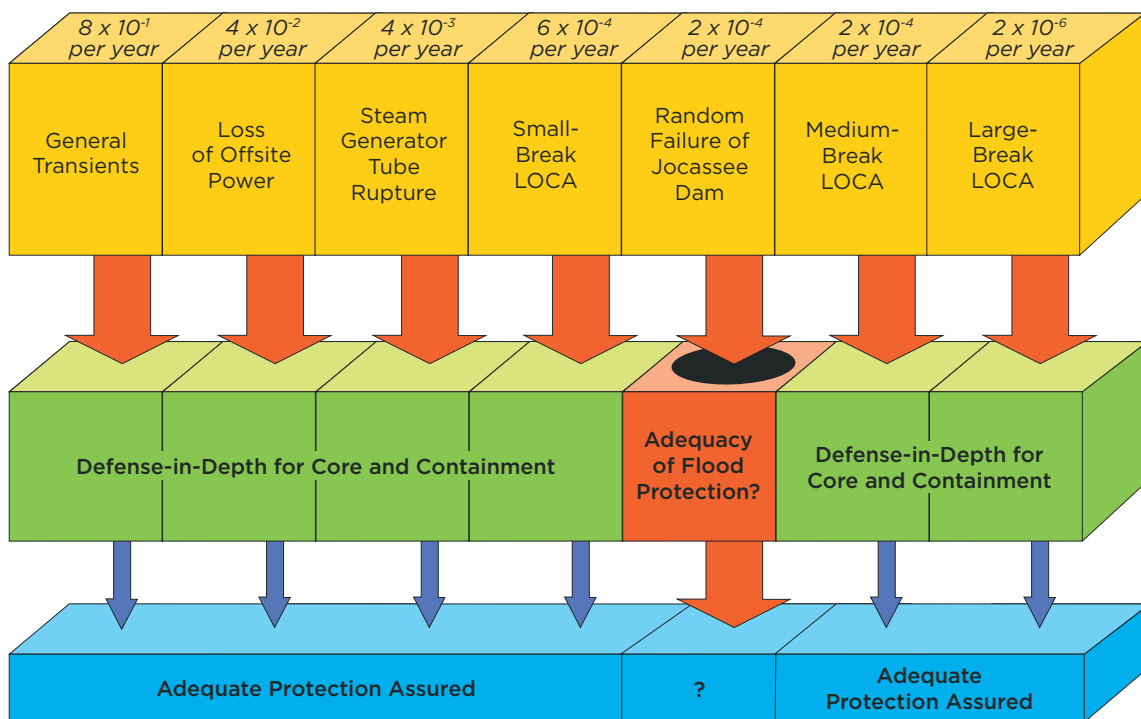

The NRC’s analysis of the risk of reactor core damage from the unresolved flood protection problems posed by a possible Jocassee Dam failure relative to other risks at Oconee. The numbers in the top row are the likelihood of the respective events happening in a given year ( $2 \times 10^{-6}$  per year corresponds to one event every 500,000 years;  $2 \times 10^{-4}$  per year corresponds to one event every 5,000 years). The NRC estimated the odds of the large tsunami that devastated Fukushima as one in 1,000 years (Rampton 2011). The green row in the middle reflects the design features installed at Oconee to protect against hazards. The blue row at the bottom reflects the NRC’s determination that the design features adequately manage the risks posed by these hazards. The figure shows that the probability of a Jocassee Dam failure is comparable to or higher than other events (top row), but measures to prevent such a failure from causing core damage are not in place (middle row), and could therefore lead to the meltdown of the reactors at Oconee (bottom row).

SOURCE: FERRANTE 2010.



Title slide from the public meeting conducted by the NRC for community members around the Oconee plant in April 2011. (Source: Bartley 2011)

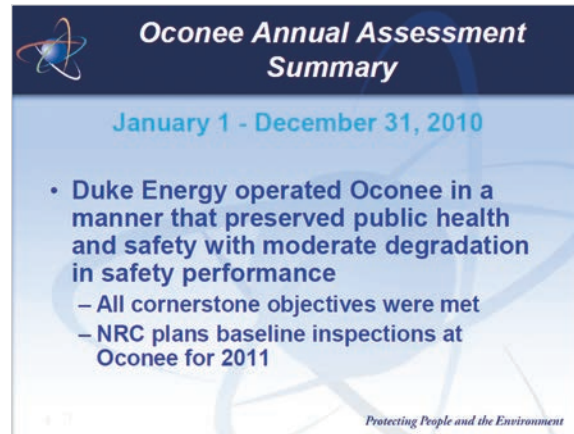

Summary slide from the NRC's public meeting. The "moderate degradation in safety performance" involved problems with a backup safety system installed in 1985 that was described in the first annual UCS nuclear safety report (Lochbaum 2011). The NRC did not inform community members that it had ordered Duke Energy to implement safety fixes for problems that could cause all three reactors to melt down, or that all of the NRC's mandated fixes had not yet been implemented. (Source: Bartley 2011)

from the public in April 2011 and provided false assurance that all was well. The NRC misrepresented the current situation at Oconee to the plant's neighbors by painting a rosier picture of conditions than they knew existed.

When a document contains security, trade-secret, or confidential personal information, the NRC should by all means withhold or redact it. But when a document lacks any such information, the NRC should by no means withhold or redact it. And it is never acceptable for the NRC to mislead the American public.

### Observations on Ineffective NRC Oversight

We cannot understand how the NRC can enforce safety regulations at Fort Calhoun, Maine Yankee, Surry, Beaver Valley, and other facilities and yet ignore them at Oconee and Diablo Canyon. Robert Louis Stevenson wrote a compelling novel about a good doctor turning into an evil entity, which has been made into a feature film several times. Good as it is, this tale need not be reprised as a regulatory drama on the NRC's stage.

The NRC did not allow Fort Calhoun's single reactor to resume operating until fire and flood protection problems were corrected. Yet the NRC allows Oconee's three and Diablo Canyon's two reactors to continue operating despite unresolved safety issues of at least equal and likely greater severity.

In 2001, the NRC allowed another reactor to operate despite known safety shortcomings. The Davis-Besse Nuclear

***The NRC did not allow Fort Calhoun to resume operating until fire and flood protection problems were corrected. Yet the NRC allows Oconee and Diablo Canyon to continue operating despite unresolved safety issues.***

Power Station in Oak Harbor, Ohio, was among a dozen reactors that the NRC required to perform safety inspections before the end of the year. Because the reactor had to be shut down in order to conduct the mandated inspections, Davis-Besse's owner resisted the NRC's request. The NRC staff applied five safety principles to determine whether it could justify postponing the inspections. They concluded that four of the safety principles were clearly not met and the fifth probably was not met. The NRC staff drafted an order that would require Davis-Besse to be shut down by the end of 2001. But senior management at the NRC buckled under pressure from the

owner, shelving the shutdown order and allowing Davis-Besse to continue operating into 2002.

After degradation of the reactor vessel head at Davis-Besse was discovered, researchers at the Oak Ridge National Laboratory estimated that the degradation could have breached the reactor vessel in as little as 60 more days—rapidly draining cooling water and challenging the safety systems intended to refill the vessel before the reactor core was damaged.

As baseball great Yogi Berra famously said, it's *déjà vu* all over again. The NRC knows that Oconee and Diablo Canyon are operating outside pre-established safety

regimes. Luck protected the people of northern Ohio as Davis-Besse's single reactor operated for months before it was finally shut down and its serious problems fixed. Luck is now protecting the people of California and South Carolina, where five reactors have operated for years with known safety problems.

The people of Nebraska had different luck. They were lucky the NRC properly enforced safety regulations and did not allow Fort Calhoun to restart until its known problems had been remedied. The NRC did right by the people of Nebraska (and Georgia) and must do right by all Americans.



The NRC allowed the Davis-Besse reactor in Ohio to operate with known safety problems.

© U.S. Nuclear Regulatory Commission/Wikimedia

## Summary and Recommendations

Chapter 2 summarizes near-misses that the NRC reported at U.S. nuclear plants last year. The lessons learned from the near-misses described in Chapter 2 are:

- The NRC and the nuclear industry should study the Arkansas Nuclear One near-miss to identify and institutionalize the elements that contributed to the successful response on the part of plant operators.
- The NRC should periodically re-inspect fixes to safety problems, such as those mandated by the agency's generic communications program, to determine whether they continue to be effective.
- The NRC should revise its license renewal process to provide assurance that reactors are operating in a manner consistent with applicable regulatory requirements.
- The NRC and the nuclear industry should protect against human performance impairment caused by fatigue at all times, not just when reactors are operating.

As Chapter 3 shows, such near-misses have been occurring at a rate of more than one per month over the past four years. Given enough chances, it seems only a matter of time before near-misses become an actual hit. Public safety would be better served by reducing the frequency of near-misses. The NRC should take two steps to better protect the public:

- Each SIT, AIT, and IIT should include a formal evaluation of the NRC's baseline inspection effort. The baseline inspection effort covers the array of routine inspections conducted by the NRC at every nuclear plant. When an SIT, AIT, or IIT identifies safety violations that contributed

to the near-miss, the NRC's evaluation should determine whether the baseline inspection effort could have, and should have, found the safety violations sooner. Such insights from the near-misses may enable the NRC to make adjustments in what its inspectors examine, how they examine it, and how often they examine it to increase the chances of finding potential violations.

- Plant owners must be required to formally evaluate why their routine testing and inspection regimes failed to find longstanding problems. Many of the near-misses in Chapter 2 involved design and operational problems that existed for years, sometimes decades. The testing and inspection regimes are intended to find and fix such problems preventively, but clearly failed to do so. Plants' programmatic weaknesses must be remedied to offer better protection against future near-misses.

Chapter 4 describes several positive outcomes achieved by the NRC last year. Positive outcomes include the NRC putting the entire state of Georgia on probation due to inadequate performance, and the NRC allowing the Fort Calhoun nuclear plant to resume operating after determining its safety shortcomings had been rectified. The NRC and its inspector general also deserve recognition for identifying gaps in the agency's oversight of aging components at nuclear power plants.

Chapter 5 reveals the NRC's dark side. The NRC shut the public out of its development of a study on accelerating the transfer of irradiated fuel from spent fuel pools to dry storage. That study provided many answers, but to none of the relevant questions.

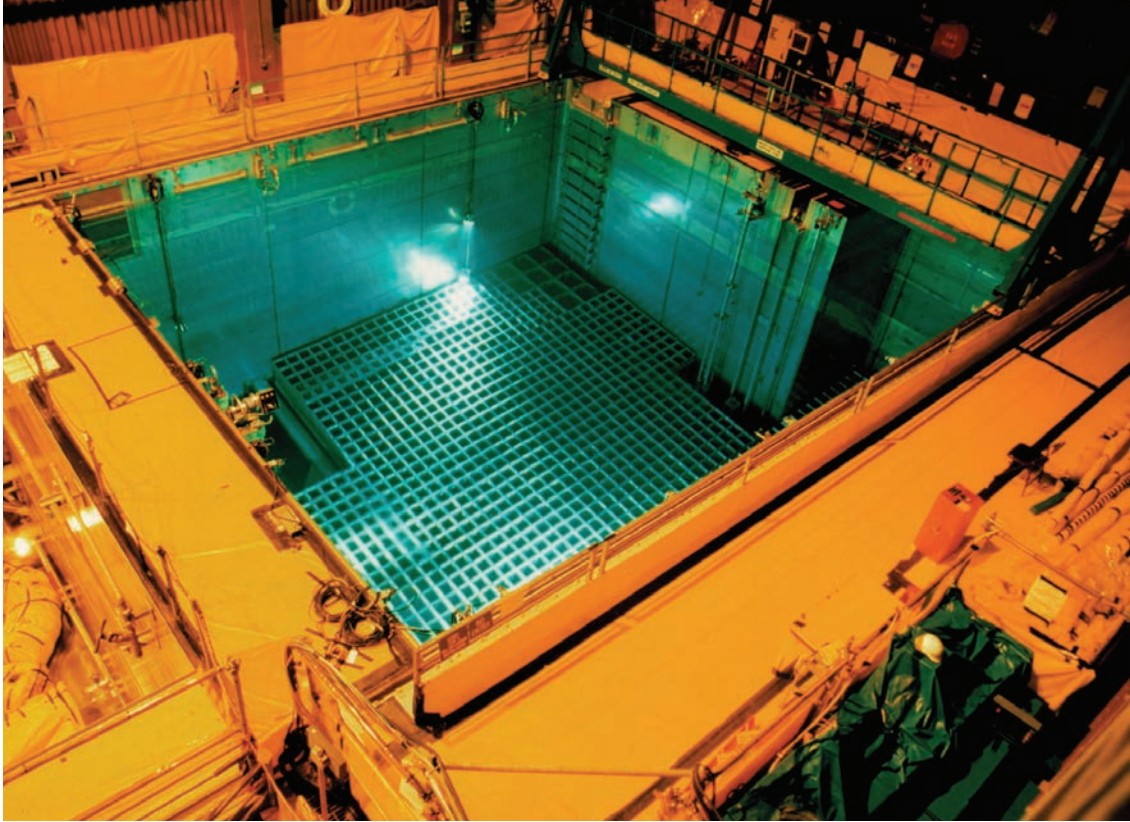

© U.S. Nuclear Regulatory Commission

*The NRC's assessment of transferring spent fuel from cooling pools to dry casks suffered from problems of process and substance.*

Worse still was the agency's bungling of safety problems at two reactors. For decades, the NRC has not allowed nuclear facilities to operate with deficient protection against earthquake hazards. But after the 2008 discovery of a new fault line near the Diablo Canyon plant in the seismically active state of California, the NRC allowed both of its reactors to operate at risk to the community.

Equally bad, the NRC dealt the community around the Oconee nuclear plant a one-two punch. In 2010, the NRC required the plant's owner, Duke Energy, to complete fixes of fire protection problems by December 31, 2012. When the company requested a two-year delay, the NRC denied it on the grounds that it was too risky to operate for so much longer without the fixes. Then in July 2013, the NRC ordered the company to complete the fixes within four years. If two years' delay is unsafe, four years' delay is insane—especially since fire regulations have been in place since 1980.

In 2013, evidence also emerged that the NRC had improperly withheld information from the public about risks to

Oconee from the potential failure of the Jocassee Dam upstream from the plant. In 2010, the NRC required Duke to complete fixes of flood protection problems associated with this possible failure. The NRC determined that if the dam failed, there was a 100 percent chance of the three reactors at Oconee melting down. But the NRC withheld this information from the public. Indeed, in April 2011, the NRC conducted a public meeting in the community to discuss results from its oversight efforts during 2010. Only one month after a flood caused three reactors at Fukushima to melt down, the NRC remained silent about the very same hazard it had ordered the company to better guard against at Oconee. The NRC misrepresented conditions at the plant to its residential neighbors.

The results from 2013 show the NRC to be more Dr. Jekyll than Mr. Hyde. While all Jekyll all the time may be an elusive goal, the NRC should strive for more Jekyll and less Hyde in its future.



## [ REFERENCES ]

- Bartley, J.H. 2011. *Public meeting summary—Oconee Nuclear Station—docket nos. 50-269, 50-270 and 50-287*. Atlanta, GA: U.S. Nuclear Regulatory Commission. April 25. Online at <http://pbadupws.nrc.gov/docs/ML1111/ML111170729.pdf>.
- Barto, A., Y.J. Chang, K. Compton, H. Esmaili, D. Helton, A. Murphy, A. Nosek, J. Pires, F. Schofer, and B. Wagner. 2013. *Consequence study of a beyond-design-basis earthquake affecting the spent fuel pool for a U.S. Mark I boiling water reactor*. Washington, DC: U.S. Nuclear Regulatory Commission. Draft. June. Online at <http://pbadupws.nrc.gov/docs/ML1313/ML13133A132.pdf>.
- Borchardt, R.W. 2011. *Prioritization of recommended actions to be taken in response to Fukushima lessons learned, SECY-11-0137*. Washington, DC: U.S. Nuclear Regulatory Commission. October 3. Online at <http://pbadupws.nrc.gov/docs/ML1126/ML11269A204.pdf>.
- Casto, C.A. 2013. *Assessment followup letter for the Perry Nuclear Power Plant and deviation from the reactor oversight process action matrix*. Lisle, IL: U.S. Nuclear Regulatory Commission. January 17. Online at <http://pbadupws.nrc.gov/docs/ML1301/ML13018A163.pdf>.
- Collins, E.E. 2010. *Final significance determination for a yellow finding and notice of violation, NRC inspection report 05000285/2010007, Fort Calhoun Station*. Arlington, TX: U.S. Nuclear Regulatory Commission. October 6. Online at <http://pbadupws.nrc.gov/docs/ML1028/ML102800342.pdf>.
- Conley, M. 2013. NRC approves probation for Georgia's Agreement State regulatory program. Washington, DC: U.S. Nuclear Regulatory Commission. Press release no. 13-065, August 8. Online at <http://pbadupws.nrc.gov/docs/ML1322/ML13220A384.pdf>.
- Criscione, L.S. 2012. Letter to NRC Chairman Allison Macfarlane. September 18. Online at <http://pbadupws.nrc.gov/docs/ML1325/ML13256A372.pdf>.
- Dapas, M.L. 2013. *Fort Calhoun Station closure of confirmatory action letter*. Arlington, TX: U.S. Nuclear Regulatory Commission. December 17. Online at <http://pbadupws.nrc.gov/docs/ML1335/ML13351A423.pdf><http://adamswebsearch2.nrc.gov/webSearch2/main.jsp?AccessionNumber=ML13351A423>'.
- Evans, M.G. 2013. *Oconee Nuclear Station, Units 1, 2, and 3, denial of amendment request regarding extension of license condition for NFPA 805 transition*. Washington, DC: U.S. Nuclear Regulatory Commission. January 15. Online at <http://pbadupws.nrc.gov/docs/ML1234/ML12345A204.pdf>.
- Ferrante, F. 2010. *Oconee flooding issue summary draft*. Rockville, MD: U.S. Nuclear Regulatory Commission. January 7. Online at <http://pbadupws.nrc.gov/docs/ML1306/ML13066A214.pdf>.
- Giitter, J.G. 2010. *Evaluation of Duke Energy Carolinas, LLC (Duke), November 30, 2009, response to Nuclear Regulatory Commission (NRC) letter dated April 30, 2009, related to external flooding at Oconee Nuclear Station, Units 1, 2, and 3 (Oconee). (TAC nos. ME3065, ME3066, and ME3067)*. January 29. Online at <http://pbadupws.nrc.gov/docs/ML1236/ML12363A085.pdf>.
- Haire, M.S. 2013a. *Columbia Generating Station—NRC security special inspection report 05000397/2013409*. Arlington, TX: U.S. Nuclear Regulatory Commission. November 7. Online at <http://pbadupws.nrc.gov/docs/ML1331/ML13312A220.pdf>.
- Haire, M.S. 2013b. *Columbia Generating Station—NRC security special inspection report 05000397/2013408*. Arlington, TX: U.S. Nuclear Regulatory Commission. April 25. Online at <http://pbadupws.nrc.gov/docs/ML1311/ML13116A035.pdf>.
- Hay, M. 2013. *Fort Calhoun Station—NRC special inspection report 05000285/2013-012*. Arlington, TX: U.S. Nuclear Regulatory Commission. May 24. Online at <http://pbadupws.nrc.gov/docs/ML1314/ML13144A772.pdf>.
- Howell, A.T. III. 2013. *Arkansas Nuclear One—NRC augmented inspection team report 05000313/2013011 and 05000368/2013011*. Arlington, TX: U.S. Nuclear Regulatory Commission. June 7. Online at <http://pbadupws.nrc.gov/docs/ML1315/ML13158A242.pdf>.
- Hunegs, G.K. 2013. *Oyster Creek generating station—NRC special inspection report 05000219/2012009*. King of Prussia, PA: U.S. Nuclear Regulatory Commission. January 10. Online at <http://pbadupws.nrc.gov/docs/ML1301/ML13010A470.pdf>.
- Kennedy, K.M. 2013. *Deferral of baseline inspection activities*. Arlington, TX: U.S. Nuclear Regulatory Commission. November 19. Online at <http://pbadupws.nrc.gov/docs/ML1332/ML13324A494.pdf>.
- Koberstein, P. 2012. FOIA for documents concerning Jocassee [sic] Dam. *Cascadia Times*, January 27. Online at <http://pbadupws.nrc.gov/docs/ML1203/ML12030A105.pdf>.
- Lantz, R. 2013. *Columbia Generating Station—NRC special inspection report 05000397/2013010*. Arlington, TX: U.S. Nuclear Regulatory Commission. December 24. Online at <http://pbadupws.nrc.gov/docs/ML1335/ML13358A326.pdf>.
- Lochbaum, D.A. 2013. *Seismic shift: The NRC and Diablo Canyon*. Cambridge, MA: Union of Concerned Scientists. November 13. Online at <http://allthingsnuclear.org/seismic-shift-the-nrc-and-diablo-canyon>.
- Lochbaum, D.A. 2011. *The NRC and nuclear power plant safety in 2010: A brighter spotlight needed*. Cambridge, MA: Union of Concerned Scientists. March. Online at [http://www.ucsusa.org/nuclear\\_power/nuclear\\_power\\_risk/safety/nrc-and-nuclear-power-2010.html](http://www.ucsusa.org/nuclear_power/nuclear_power_risk/safety/nrc-and-nuclear-power-2010.html).
- McCree, V.M. 2013. *Watts Bar Unit 1 nuclear plant—final significance determination of yellow finding, white finding and notices of violations; assessment follow-up letter; inspection report no. 05000390/2013009*. Atlanta, GA: U.S. Nuclear Regulatory Commission. June 4. Online at <http://pbadupws.nrc.gov/docs/ML1315/ML13155A572.pdf>.
- McCree, V.M. 2012. *Final significance determination of white finding and notice of violation (NRC inspection report no. 05000259/2012013, 05000260/2012013, and 05000296/2012013, Browns Ferry Nuclear Plant); follow-up assessment letter*. Atlanta, GA: U.S. Nuclear Regulatory Commission. August 13. Online at [http://www.nrc.gov/NRR/OVERSIGHT/ASSESS/LETTERS/bf\\_2012q3.pdf](http://www.nrc.gov/NRR/OVERSIGHT/ASSESS/LETTERS/bf_2012q3.pdf).

- McCree, V.M. 2011. *Final significance determination of white findings and notice of violation (NRC inspection report no. 05000261/2011008; H.B. Robinson Steam Electric Plant) and assessment follow-up letter*. Atlanta, GA: U.S. Nuclear Regulatory Commission. January 31. Online at <http://pbadupws.nrc.gov/docs/ML1103/ML110310469.pdf>.
- Miller, C.G. 2013. *Susquehanna Steam Electric Station Unit 2—NRC special inspection report 05000388/2013007*. King of Prussia, PA: U.S. Nuclear Regulatory Commission. March 21. Online at <http://pbadupws.nrc.gov/docs/ML1308/ML13080A158.pdf>.
- Miller, C., A. Cabbage, D. Dorman, J. Grobe, G. Holahan, and N. Sanfilippo. 2011. *Recommendations for enhancing reactor safety in the 21st century: The Near-Term Task Force review of insights from the Fukushima Dai-ichi accident*. Washington, DC: U.S. Nuclear Regulatory Commission. July 12. Online at <http://pbadupws.nrc.gov/docs/ML1118/ML111861807.pdf>.
- Mitlyng, V., and P. Chandrathil. 2013. The NRC will keep Perry Nuclear Power Plant in current performance column. Press release III-13-02. Lisle, IL: U.S. Nuclear Regulatory Commission. January 18. Online at <http://pbadupws.nrc.gov/docs/ML1301/ML13018A432.pdf>.
- Nuclear Regulatory Commission (NRC). 2011. *NRC inspection manual*. Manual chapter 0309—Reactive inspection decision basis for reactors. Washington, DC. October 28. Online at <http://pbadupws.nrc.gov/docs/ML1118/ML111801157.pdf>.
- Nuclear Regulatory Commission (NRC). 2008. *Briefing on fire protection issues*. Washington, DC: U.S. Nuclear Regulatory Commission. July 17. Online at <http://www.nrc.gov/reading-rm/doc-collections/commission/tr/2008/20080717.pdf>.
- Office of the Inspector General (OIG). 2013. *Audit report: Audit of NRC's oversight of active component aging*. OIG-14-A-02. Washington, DC: U.S. Nuclear Regulatory Commission. October 28. Online at <http://pbadupws.nrc.gov/docs/ML1330/ML1330IA638.pdf>.
- Partlow, J.G. 1989. *Service water system problems affecting safety-related-equipment (Generic letter 89-13)*. Washington, DC: U.S. Nuclear Regulatory Commission, July 18. Online at <http://www.nrc.gov/reading-rm/doc-collections/gen-comm/gen-letters/1989/gl89013.html>.
- Pederson, C.D. 2013. *Final significance determination of a yellow finding with assessment followup and notice of violation; NRC inspection report no. 05000263/2013009; Monticello Nuclear Generating Plant*. Lisle, IL: U.S. Nuclear Regulatory Commission. August 28. Online at <http://pbadupws.nrc.gov/docs/ML1324/ML13240A435.pdf>.
- Rampton, R. 2011. Fukushima disaster not “unforeseen”—NRC commissioner. Washington, DC: Reuters. August 3. Online at <http://www.reuters.com/article/2011/08/03/usa-nuclear-apostolakis-idAFN1E77211Y20110803>.
- Reis, T. 2013a. *Browns Ferry Nuclear Plant—NRC special security inspection report 05000259/2013405, 05000260/2013405 and 05000296/2013405*. Atlanta, GA: U.S. Nuclear Regulatory Commission. July 17. Online at <http://pbadupws.nrc.gov/docs/ML1319/ML13199A148.pdf>.
- Reis, T. 2013b. *Shearon Harris nuclear plant—NRC special inspection report 05000400/2013010*. Atlanta, GA: U.S. Nuclear Regulatory Commission. July 10. Online at <http://pbadupws.nrc.gov/docs/ML1319/ML13192A154.pdf>.
- Reyes, L.A. 2010. *Confirmatory action letter—Oconee Nuclear Station, Units 1, 2, and 3 commitments to address external flooding concerns. (TAC nos. ME3065, ME3066, and ME3067)*. Atlanta, GA: U.S. Nuclear Regulatory Commission. June 22. Online at <http://pbadupws.nrc.gov/docs/ML1236/ML12363A086.pdf>.
- Reynolds, S. 2013. *LaSalle County Station, Units 1 and 2—NRC special inspection team (SIT) inspection report 05000373/2013009; 05000374/2013009*. Lisle, IL: U.S. Nuclear Regulatory Commission. July 18. Online at <http://pbadupws.nrc.gov/docs/ML1319/ML13199A512.pdf>.
- Sebrosky, J. 2012. *Diablo seismic issues DORL-DE-DRA briefing*. Washington, DC: U.S. Nuclear Regulatory Commission. February 9. Online within package FOIA/PA no: 2014-0065 (Group B) at <http://pbadupws.nrc.gov/docs/ML1335/ML13354B992.pdf>.
- Stone, A.M. 2011. *LaSalle County Station, Units 1 and 2 component design bases inspection (CDBI) 05000373/2010006(DRS); 05000374/2010006(DRS)*. Lisle, IL: U.S. Nuclear Regulatory Commission. February 15. Online at <http://pbadupws.nrc.gov/docs/ML1104/ML110460708.pdf>.
- Thompson, J.W. 2013. *IOEB analysis team study on component aging—Insights from inspection findings and reportable events*. Washington, DC: U.S. Nuclear Regulatory Commission. February 19. Online at <http://pbadupws.nrc.gov/docs/ML1304/ML13044A469.pdf>.
- Vinyard, H.T. 2013. *Licensee event report 2013-002-001 unusual event declared due to loss of offsite power and dual unit scram*. Marseillies, IL: Exelon Generation. July 26. Online at <http://adamswebsearch2.nrc.gov/webSearch2/main.jsp?AccessionNumber='ML13207A371'>.
- Weber, M.F. 2013. *Letter to Judson H. Turner, director, Georgia Department of Natural Resources*. Washington, DC: U.S. Nuclear Regulatory Commission. February 5. Online at <http://pbadupws.nrc.gov/docs/ML1302/ML13023A380.pdf>.
- Wright, D. 2013. NRC denies Oconee fire reg extension, but what will it do now? Cambridge, MA: Union of Concerned Scientists. January 24. Online at <http://allthingsnuclear.org/nrc-denies-oconee-fire-reg-extension-but-what-will-it-do-now>.
- Zimmerman, R.P. 2013. *Notice of violation and confirmatory order related to a fire protection program license condition (Oconee Nuclear Station, Units 1, 2, and 3)*. Washington, DC: U.S. Nuclear Regulatory Commission. July 1. Online at <http://pbadupws.nrc.gov/docs/ML1311/ML13114A928.pdf>.

NOTE: All online sources were accessed on February 12 and 13, 2014.



# The NRC and Nuclear Power Plant Safety in 2013

*More Jekyll, Less Hyde*

***The NRC is capable of enforcing its safety regulations—yet we repeatedly find its enforcement to be not timely, consistent, or effective.***

The U.S. Nuclear Regulatory Commission (NRC) is charged with enforcing safety regulations at U.S. nuclear power plants to protect the public from harm. To do this it must actively monitor reactors and aggressively engage with owners and workers when it does find safety violations.

The Union of Concerned Scientists has evaluated safety issues at U.S. nuclear power plants for more than 40 years. We have repeatedly found the NRC to be capable of enforcing its safety

regulations—yet we have also repeatedly found its enforcement to be not timely, consistent, or effective.

This report, like its three predecessors, examines NRC actions during the previous year and chronicles what the commission did right and what it did wrong. Our goal is to help the NRC achieve more of the former and avoid more of the latter—before an avoidable accident costs American lives.

**Union of  
Concerned Scientists**

FIND THIS DOCUMENT ONLINE: [www.ucsusa.org/nrc2013](http://www.ucsusa.org/nrc2013)

*The Union of Concerned Scientists puts rigorous, independent science to work to solve our planet's most pressing problems. Joining with citizens across the country, we combine technical analysis and effective advocacy to create innovative, practical solutions for a healthy, safe, and sustainable future.*

#### **NATIONAL HEADQUARTERS**

Two Brattle Square  
Cambridge, MA 02138-3780  
Phone: (617) 547-5552  
Fax: (617) 864-9405

#### **WASHINGTON, DC, OFFICE**

1825 K St. NW, Suite 800  
Washington, DC 20006-1232  
Phone: (202) 223-6133  
Fax: (202) 223-6162

#### **WEST COAST OFFICE**

2397 Shattuck Ave., Suite 203  
Berkeley, CA 94704-1567  
Phone: (510) 843-1872  
Fax: (510) 843-3785

#### **MIDWEST OFFICE**

One N. LaSalle St., Suite 1904  
Chicago, IL 60602-4064  
Phone: (312) 578-1750  
Fax: (312) 578-1751